

Cap Camarat

# 12.5 WA

12.5 WA - 11/2023



## SUMMARY

- SPECIFICATIONS
- KEY POINTS
- EXTERIOR
- INTERIOR
- ATMOSPHERES
- ELECTRNIC PACKAGES
- TECHNICAL DATAS

### WARNING !

This training material is intended to Jeanneau dealers only. It may content some confidential info and competitor comparison. Please do not publish on public websites nor on social media.



JEANNEAU



## MAIN SPECIFICATIONS

### Overall length :

With platforms .....	12,27m / 40'3"
Hull length .....	10,66m / 34'11"
Deadrise .....	21°
Beam .....	3,57m / 11'8"
Draft (engines up).....	0,82m / 2'8"
Draft (engines down).....	1,10m / 3'6"
Air draft :	
without T-top .....	2,70m / 8'10"
Mini with T-top (Fiberglass) .....	3,15m / 10'4"
Mini with T-top with options .....	3,76m / 12'4"
Weight without engine, without T-top.....	5860 kg / 12919 Lbs
Max engine power .....	3x 300 hp / 3x 333 Kw

Height of outboard engines shaft .....	30" (XXL) + 2x 25" (XL)
Fuel capacity .....	1150 L
Water capacity .....	200 L
Berths .....	5
Cabins .....	2
CE Category .....	B - 11 / C - 12
Designers .....	Sarrazin Design /
.....	Michaël Peters Design / Jeanneau Design

## CAP CAMARAT 12,5 WA : POWERFUL EXPERIENCES !

**The new Cap Camarat 12.5 WA refines more than ever the spirit of the Cap Camarat. It enters the luxurious world of large outboard day cruisers.** Entrusted to the most renowned designers – Michael Peters Design and Sarrazin Design – the Cap Camarat 12.5 WA is notable for its perfectly balanced, pure and sporty hull lines.

## INTERIOR, ABSOLUTE COMFORT AND LUXURY

**Designed for cruising as well as luxury day boating**, the Cap Camarat 12.5 WA features a large forward saloon that transforms into a berth, and a **superb private aft cabin**.

**Luxury and space abound in the master cabin**, with its **king size berth, sofa and sea views**. The proximity and generous space of the head compartment further contribute to the atmosphere of luxury. The interior galley, offering privacy on board, is equipped to the highest standards (refrigeration, cooking, storage).

**Excellent performance...**

**By entrusting the design of its tapered V-shaped hull by Michael Peters**, based on criteria of the highest standards, Jeanneau can boast one of the world's greatest talents for powering its new Cap Camarat 12.5 WA **in twin and even triple engines, for up to 900 HP**. Obviously, you can expect **excellent performance from this exceptional hull!**

## EXTERIOR, NEW APPROACH TO THE OUTBOARD POWERBOAT

**Perfect ergonomic design and maximum comfort** : the Cap Camarat 12.5 WA offers two magnificent exterior living spaces.

The forward cockpit **represents true innovation**, with a versatile saloon configuration featuring a side table and three spacious sun loungers.

An aft cockpit with a **very comfortable L-shaped saloon** is accessed by the aft swim platform and a side door to starboard. **An electrically controlled drop-down terrace** on the port side **extends the cockpit to the sea**, creating a new, **very safe** swim platform, located far from the motors

A central element aboard this party boat, **the multiconfiguration exterior galley becomes a gathering place on board**.

**The helm station**, entirely devoted to driving, features a **leaning post with three seats and perfect ergonomics**. The driving and safety equipment are perfectly located close at hand and the space is generous enough to accommodate multifunction display screens of up to 16'.

While the helm station can be protected by the **superb, fully equipped T-TOP** with stainless steel structure, the two cockpits can be sheltered by the sun awnings, perfectly suited to any type of cruising.

FAST, ELEGANT AND WELL BALANCED CRUISING BOAT



The Cap Camarat 12.5 WA has a new hull **without step.**

The aim of this hull without step is to allow :

- A fast acceleration and a low speed planning

FAST, ELEGANT AND WELL BALANCED CRUISING BOAT

New hull  
Without step  
by Michael Peters



**INFUJECTION** Technology



The deep-V hull design has a sharp entry, two lifting strakes, and a spray-reducing chine that extends the full length of the hull, providing predictable handling and exceptional comfort across a wide range of conditions.

PROCESS

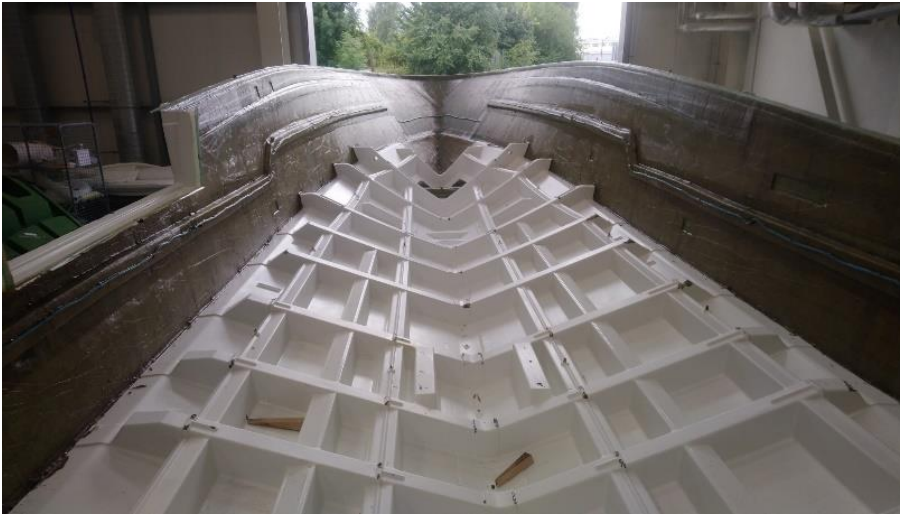

**HIGH-END INFUSION TECHNOLOGY (Jeanneau patent) :**

**Mix of 2 technologies : infusion and injection**

**ADVANTAGES :**

- Stronger and stiffer : **Stringers and hull are one single part**
- Lighter : More fiberglass and less resin
- White gelcoat on hull bottoms
- Reduction of environmental impact

LARGE LUXURIOUS DAYBOAT

Excellent circulation on board :

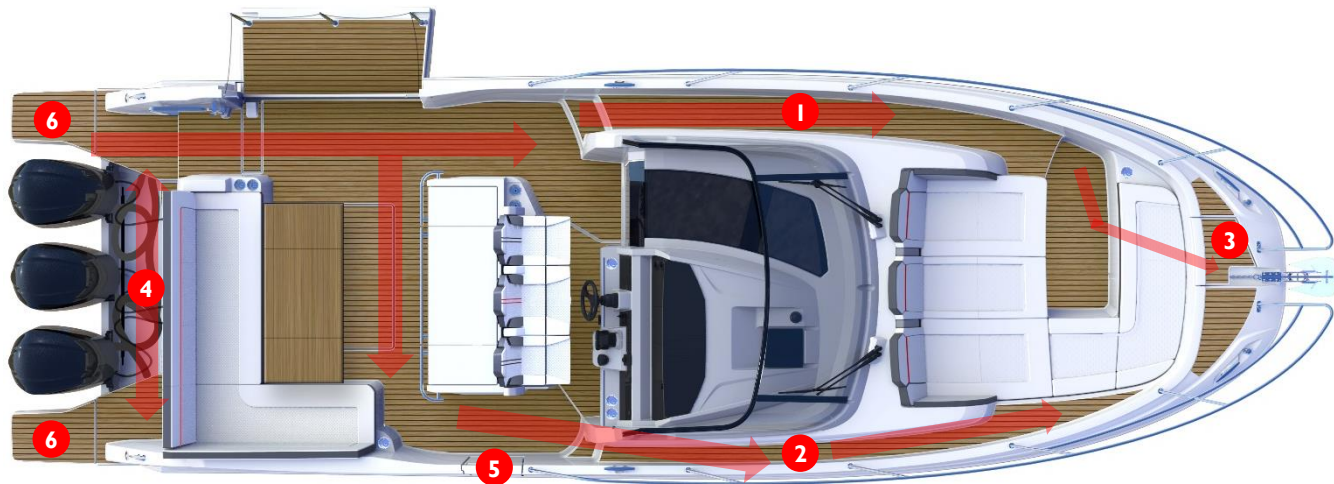

- 1** - Recessed side deck on port
- 2** - Secondary sidewalk (easy docking)
- 3** - Easy access to the anchor locker
- 4** - Easy circulation in front of the engines
- 5** - Side boarding gate (easy docking) :
- 6** - Big aft flush platforms

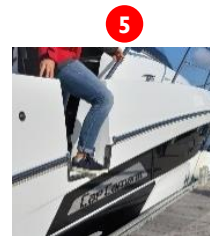

LARGE LUXURIOUS DAYBOAT WITH TWO EXTERIOR LIFE SPACES

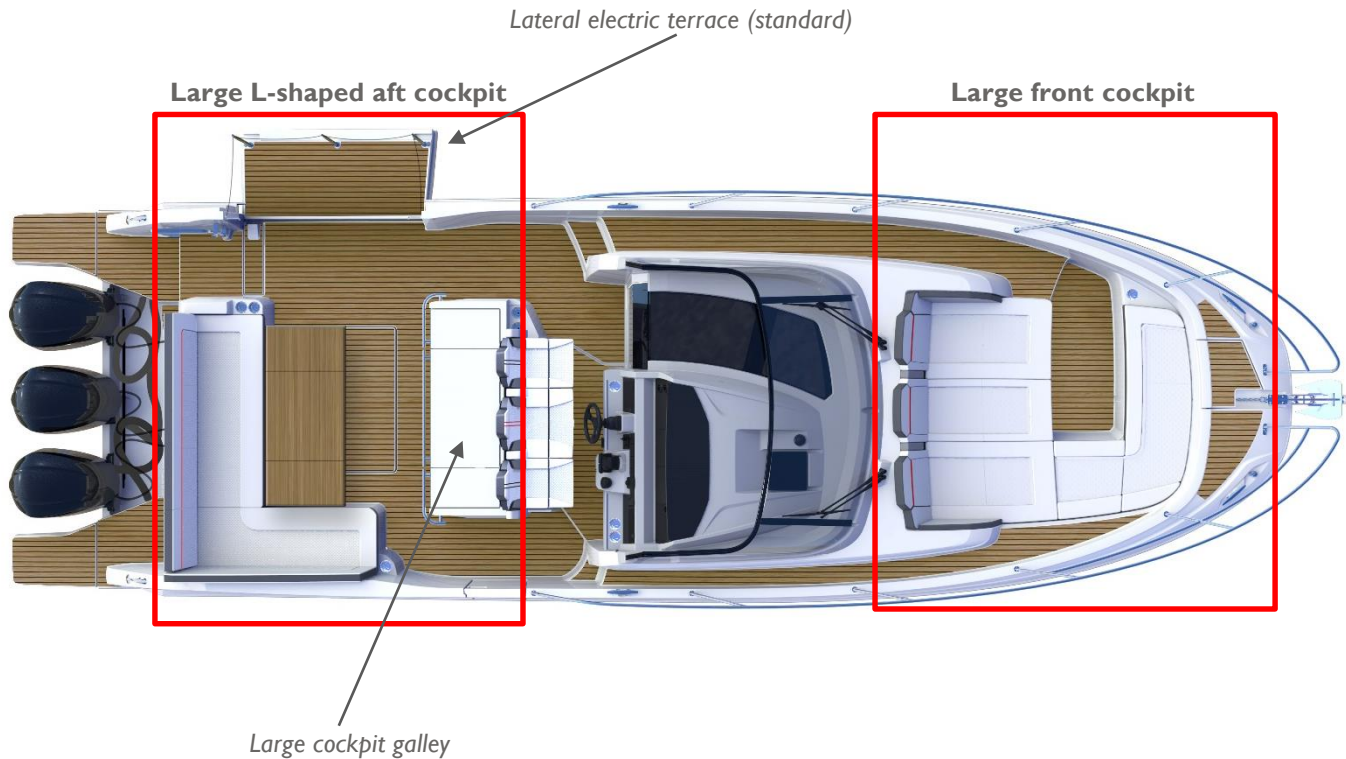



A LARGE AFT SUNPAD AND A LARGE FRONT SUNPAD

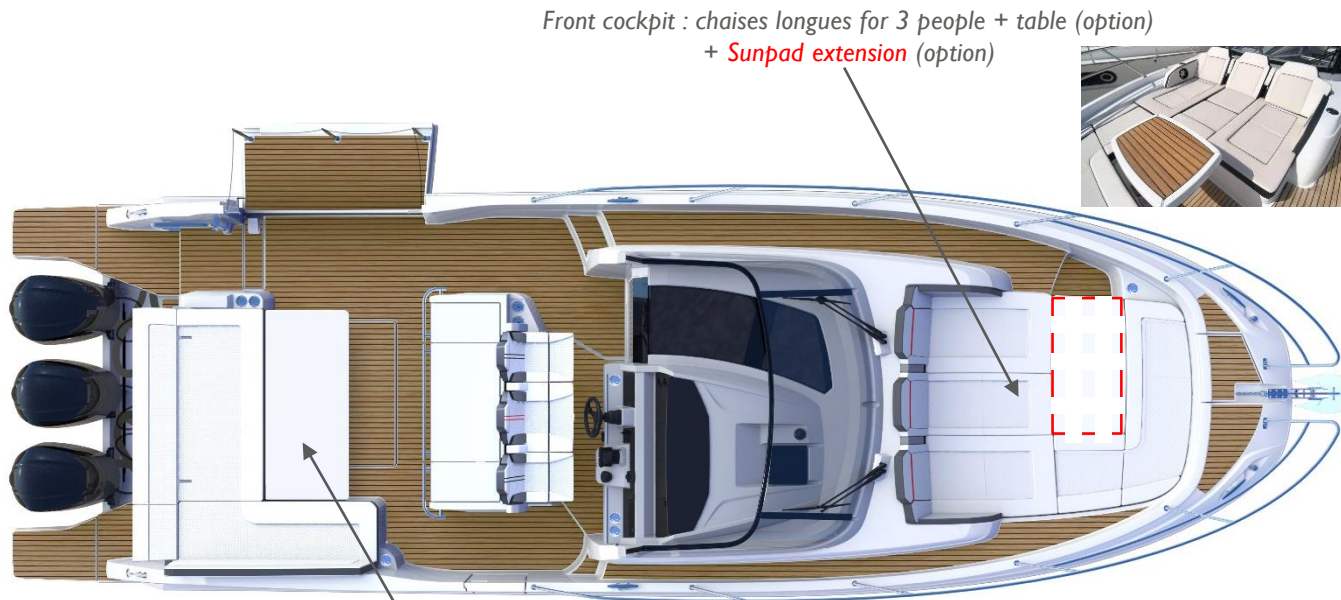

Front cockpit : chaises longues for 3 people + table (option)  
+ **Sunpad extension** (option)



Foldable backrest + table  
convertible into sunpad (option)

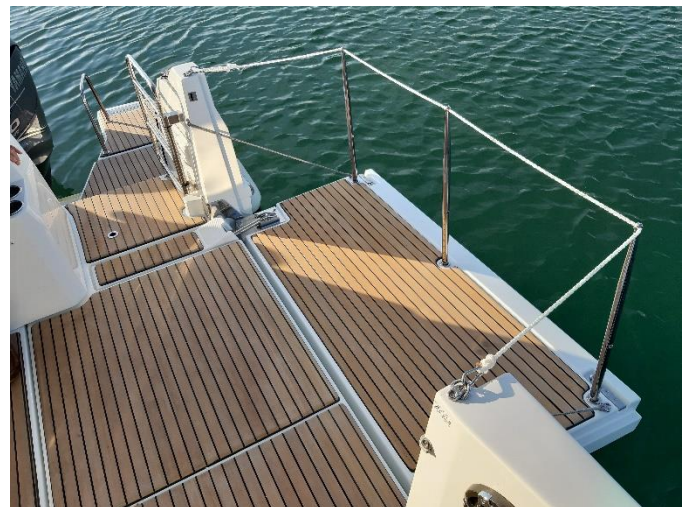

**Standard :**  
*New lateral electric terrace with removable life lines*

**Option :**  
*Terrace boarding ladder*





**Deep and comfortable L cockpit**

**Option shown : *Fiberglass table on removable legs***



**Deep and comfortable L cockpit**

**Option shown :**

*Telescopic cockpit table in teak, convertible into a large sunpad with the foldable backrest of the bench*



**Option :** *Fischer Panda 6,4 KVA generator with dedicated tank (30L / 8 US Gal) + deck fill*

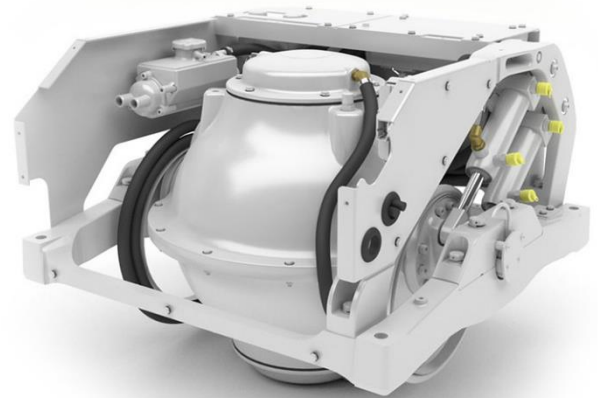

Option : Seakeeper SK3

Removable  
partition



**Multifunctional draining locker below starboard seat :**

- Fender storage
- Ice tray under starboard seat (190L / 50 US Gal)

## COCKPIT GALLEY



- Cockpit Galley**
- Centrally located
  - Customizable to fit your boating needs



COCKPIT GALLEY

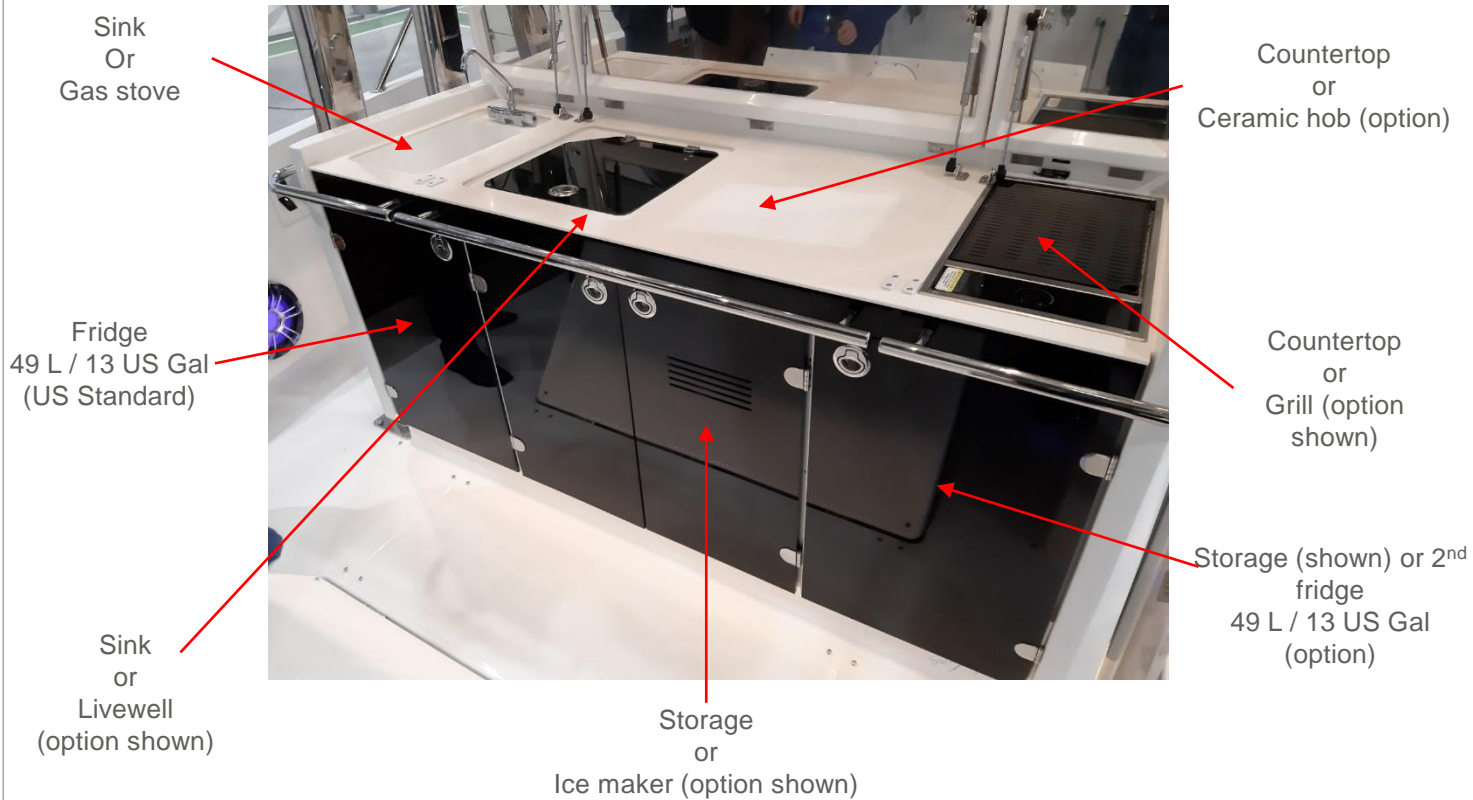

COCKPIT GALLEY

### Standard Galley

Sinks

Countertop

Fridge 49 L / 13 US Gal  
(US Standard)

Storage

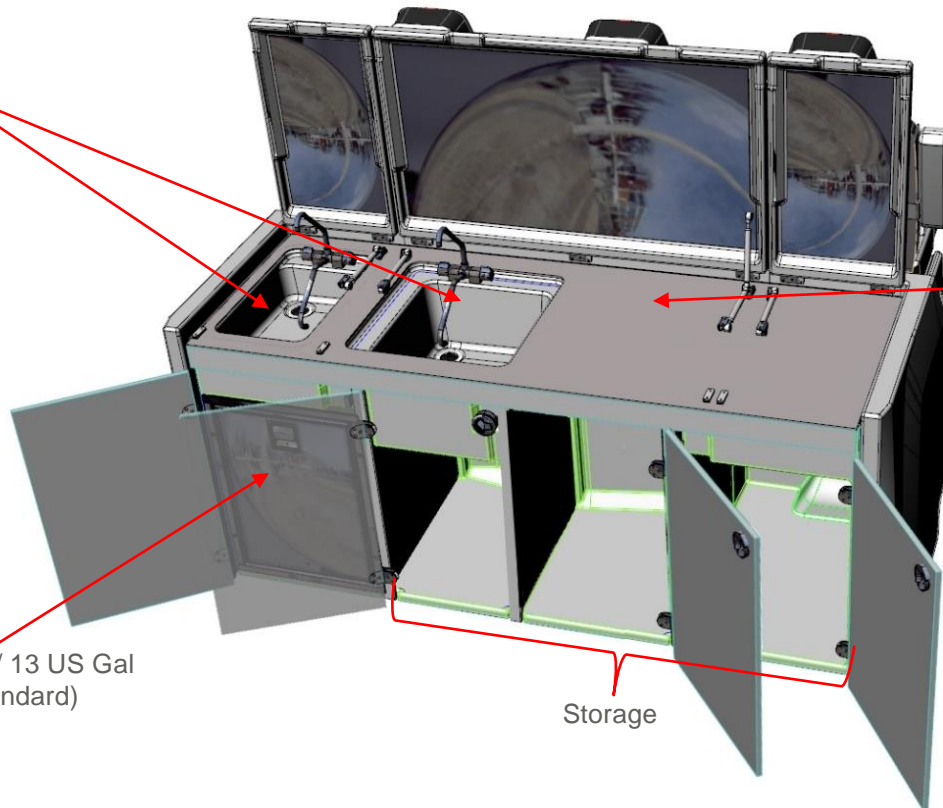

COCKPIT GALLEY

Galley with options

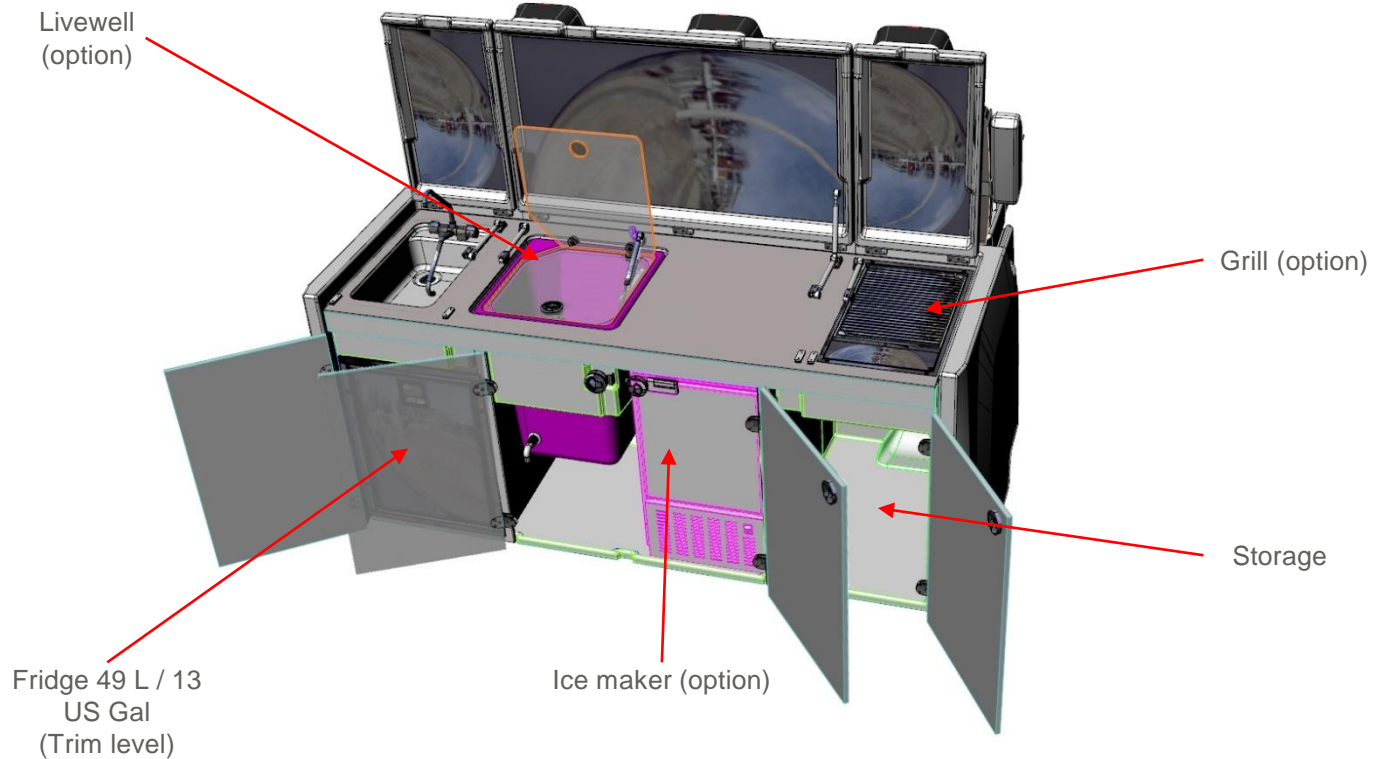

COCKPIT GALLEY

Galley with options

Gas stove (option)

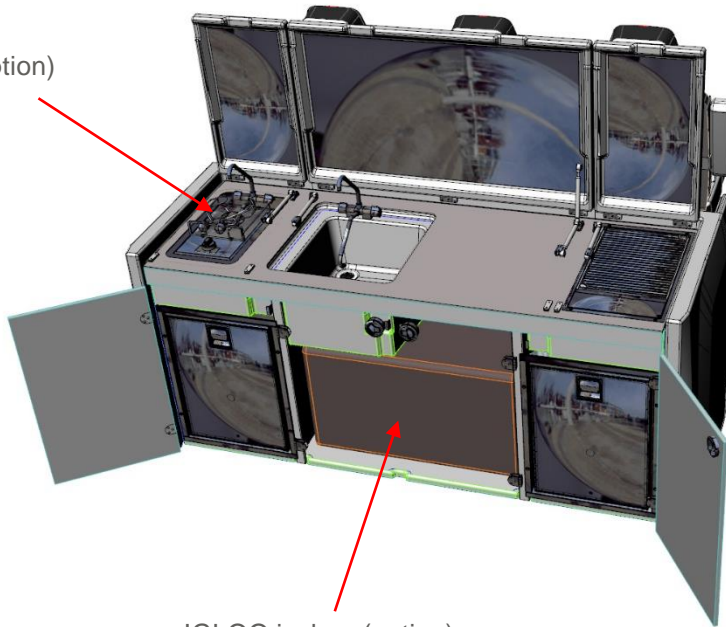

IGLOO icebox (option)

COCKPIT GALLEY

Galley with options

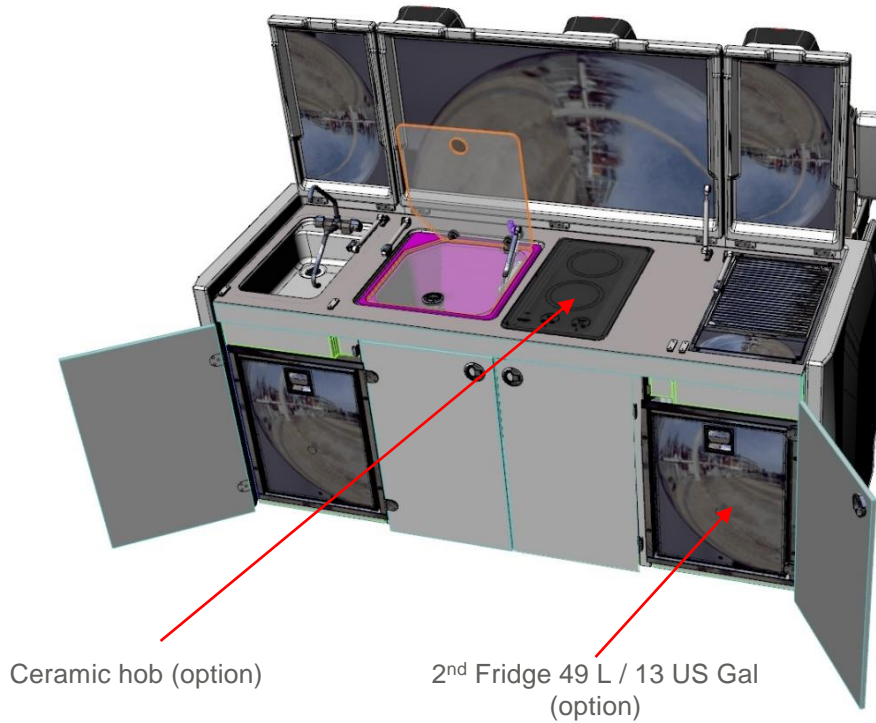

Ceramic hob (option)

2<sup>nd</sup> Fridge 49 L / 13 US Gal  
(option)

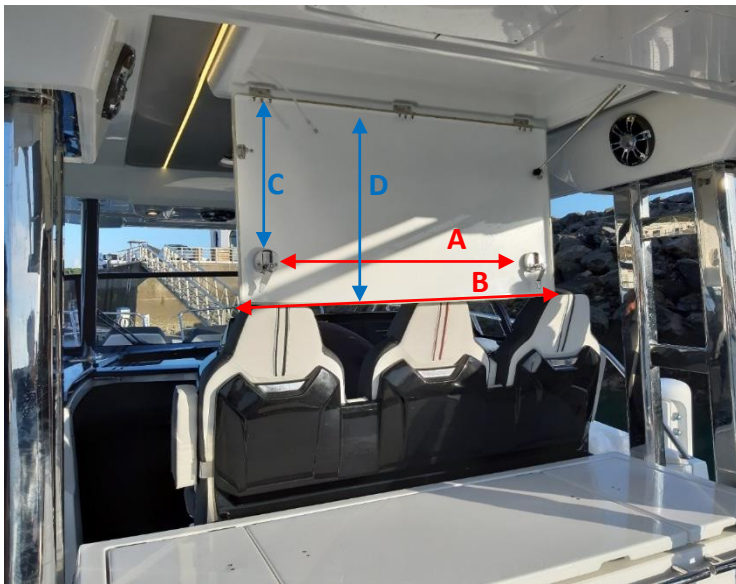

### Cockpit TV locker (≈32"-40")

Option : pre wiring + 110V plug + TV cable (TV not supplied)

Approx. Width	A : 87cm / 34"	B : 101cm / 39"
Approx. Height	C : 47cm / 18,5"	D : 54cm / 21"
Approx. Depth.	10cm / 3,9"	



**Trim Level :**

*Sunpad : Sun loungers for 3 people*



**Options :**

- *Fiberglass front cockpit table*
- *Sunpad extension with aluminium frame*





**Central helm station with 3 bolster seats and armrests  
Very large dashboard which can house 2 Garmin 12" or 2 x Garmin 16"**





**Option :** *Removable exterior cockpit carpets (with snaps)*

5 BERTHS IN 2 SEPARATED SPACES

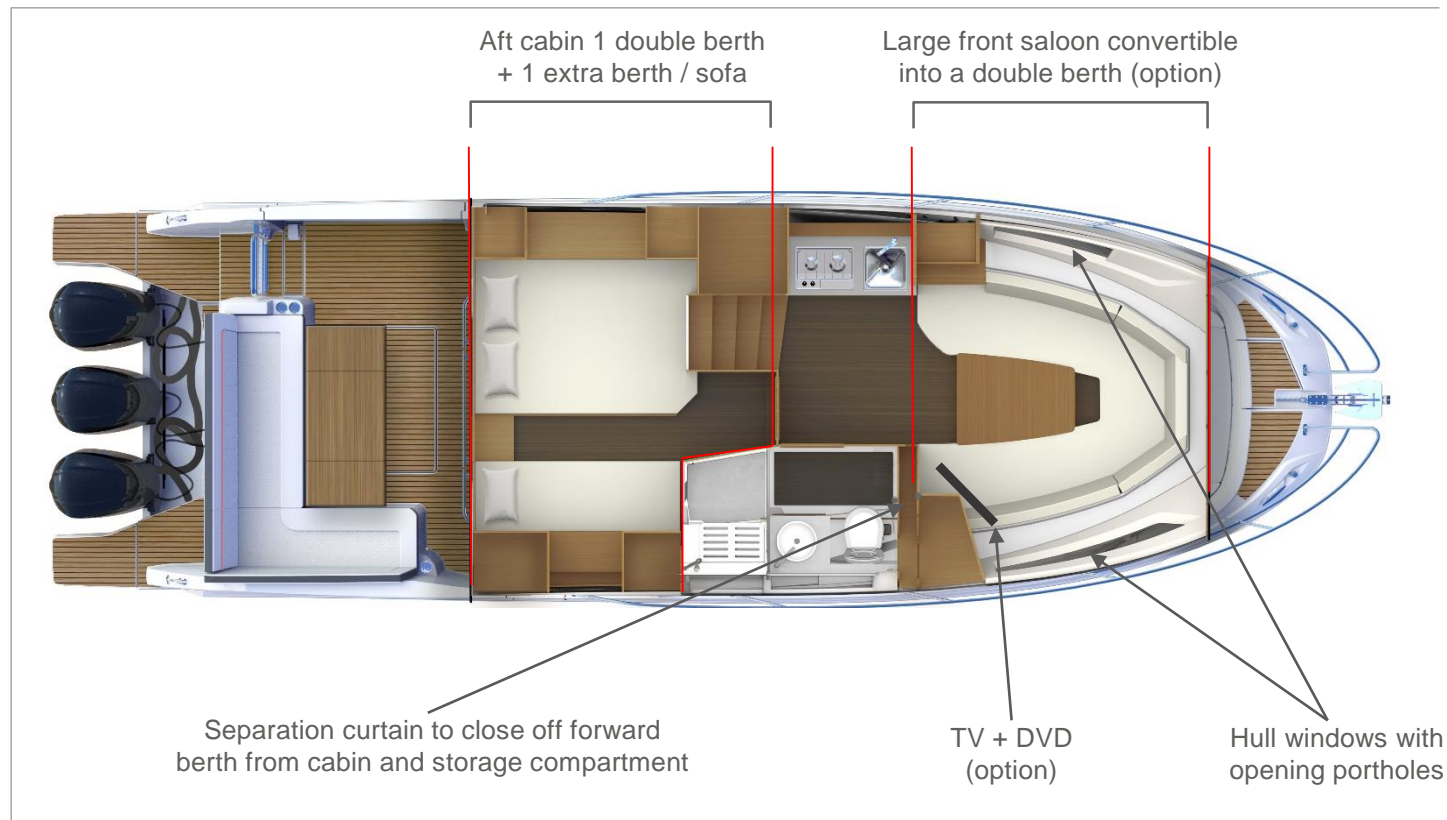

BERTHS DIMENSIONS

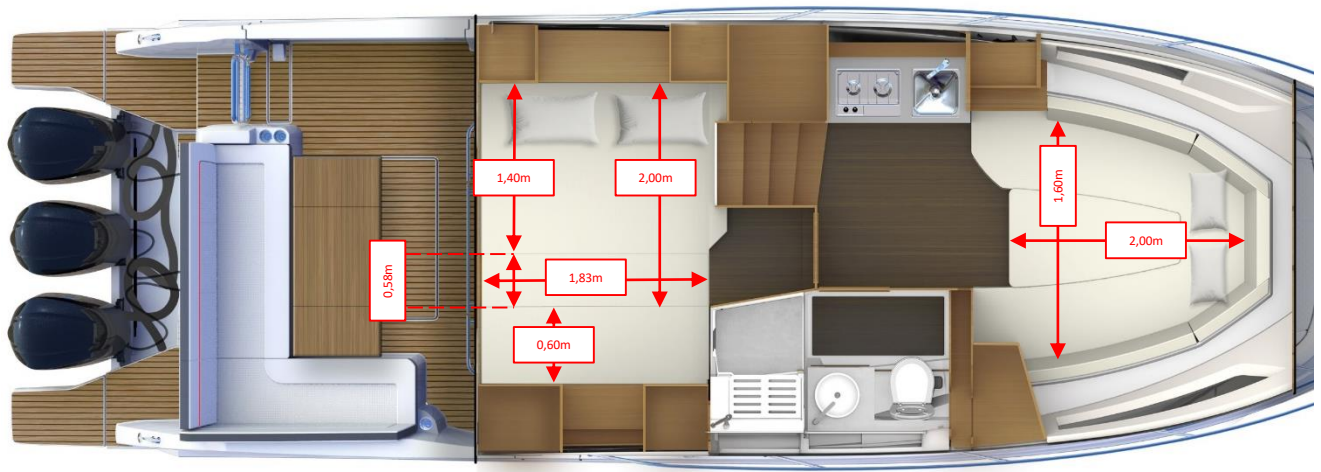

LARGE COMFORTABLE SALON



**Large salon convertible into a double berth (option) and separated by a curtain (standard)**

EQUIPED INTERIOR GALLEY

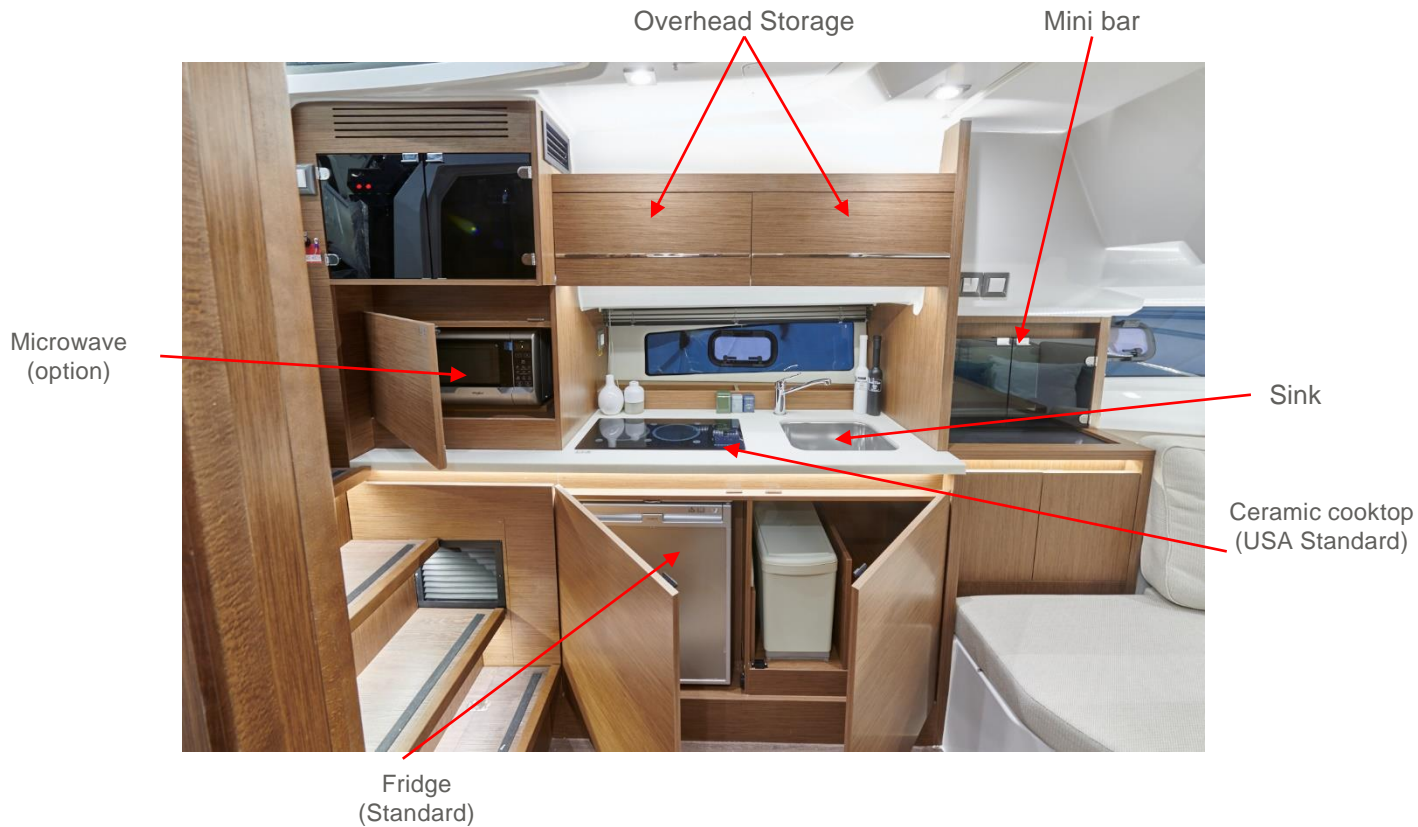

Overhead Storage

Mini bar

Microwave  
(option)

Sink

Ceramic cooktop  
(USA Standard)

Fridge  
(Standard)

LARGE HEAD WITH SEPARATED SHOWER



- Indirect LED lighting
- Sink installed on the countertop in Corian
- Excellent ventilation (opening deck windows + porthole)
- Transparent shower wall
- Electric WC with fresh water + waste tank and macerator (standard)

AFT SEPARATED CABIN FULL BEAM



**High Headroom :**  
*2,15m / 7'0" in cabin entrance to dress  
80cm / 32" aprox. above the bed to sit comfortably*

SEPARATED AFT CABIN FULL BEAM

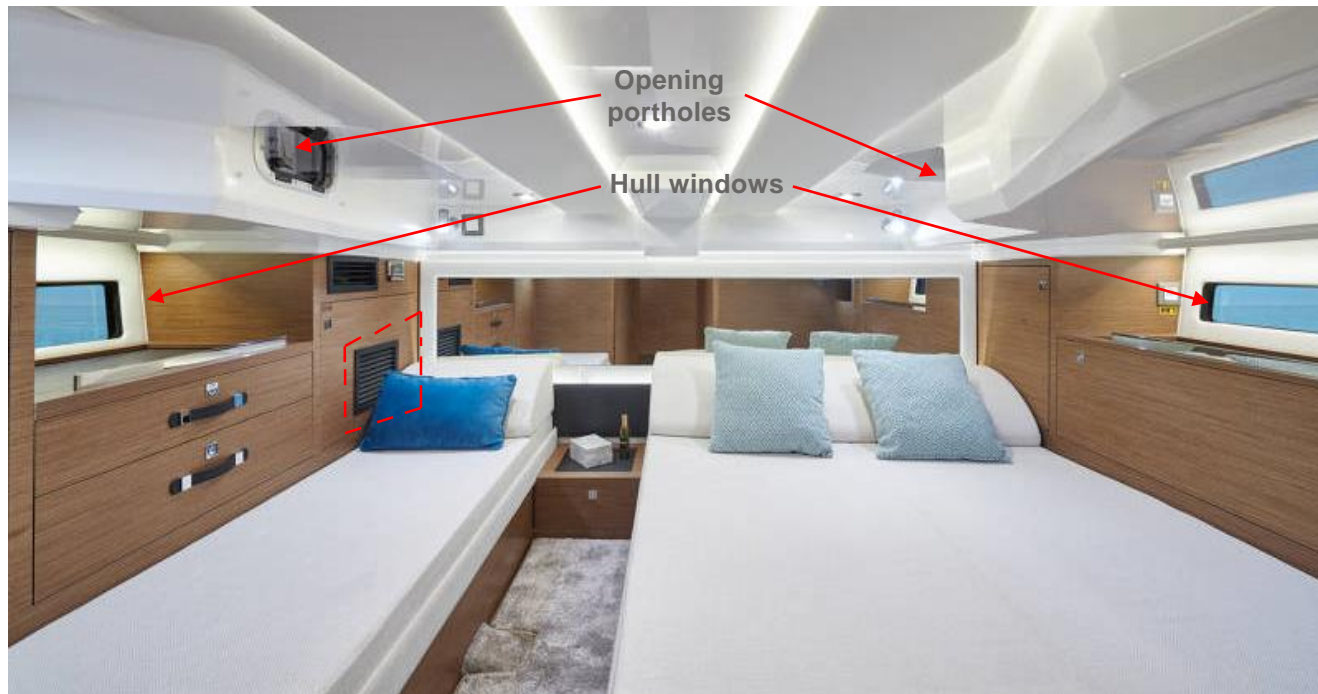

**Excellent ventilation**

**Option : 12,000 + 8,000 BTU air conditioning**



SEPARATED AFT CABIN FULL BEAM



- Vanity drawer
- Storage drawers
- Hanging locker



- Filler cushion for king size bed (option)
- Large storage under the bed



SEPARATED AFT CABIN FULL BEAM



**Option :** *Aft cabin TV + 110V plug + TV cable + DVD player*

COVERS AND SUN PROTECTION



**Bow Sun Shade option :**  
*Front sunshade with removable carbon poles*



**Aft cockpit sun shade options :**  
*- Remote controlled electrical sunshade  
or  
- Aft sunshade with removable carbon poles*

## COVERS AND SUN PROTECTION



**Option :** T-Top enclosure

● Front parts in Lexan : perfect transparency

● Separated aft parts : can be rolled up

COVERS AND SUN PROTECTION

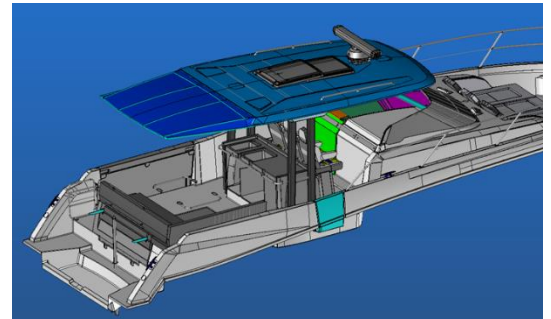
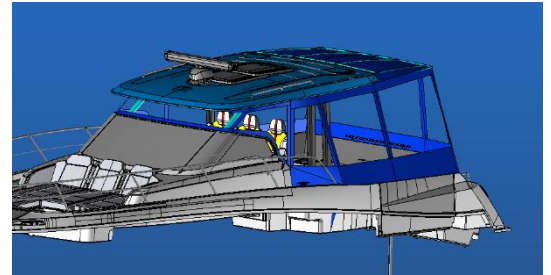
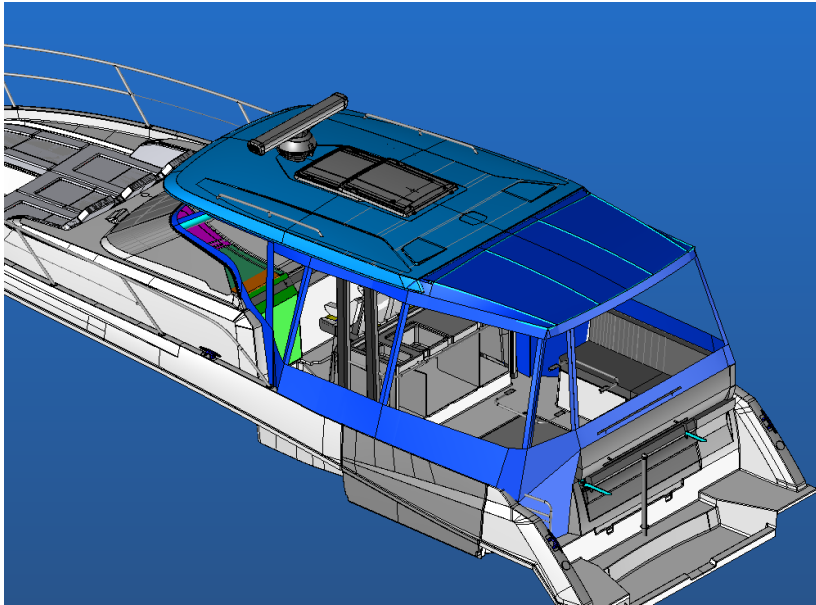

**Option :** *Aft cockpit enclosure*  
(Fixed sun awning + removable side curtains)

12.5 WA

EXTÉRIEUR / EXTERIOR

UPHOLSTERY

STANDARD

OPTION

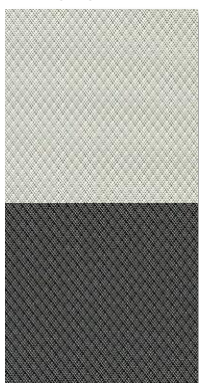

SILVERTEX ICE/  
DIAMANTE SNOV /  
DIAMANTE  
CARBON /  
DIAMANTE LAVA

DIAMANTE  
MOONLIGHT /  
DIAMANTE METEOR

SUNSHADES



SUNBRELLA  
SILVER

SUNBRELLA  
GRAPHITE

AWNINGS



SUNBRELLA  
DARK SMOKE

SUNWORKER  
CHARCOAL \*

COVERS



PVC  
STAMOID  
WHITE

*Sunbrella dark smoke : T-TOP enclosure / Cockpit enclosure / Sureshade  
Sunworker Charcoal: Front and aft sun shades on carbon poles*

## 12.5 WA

### INTÉRIEUR / INTERIOR

#### SELLERIE / UPHOLSTERY

Saloon :

STANDARD



MARLIN PURE  
WHITE (PVC)

OPTION

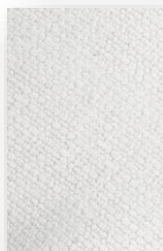

JUMBO 08 PURE

Aft cabin :

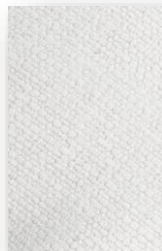

JUMBO 08 PURE

#### MENUISERIES (Standard) / WOOD

MEUBLES /  
FURNITURES

WALNUT

FLOORBOARD /  
PLANCHERS

BROWN OAK



## ELECTRONIC PACK

### GPSMAP I223xsv

MFD with multitouch 12" screen

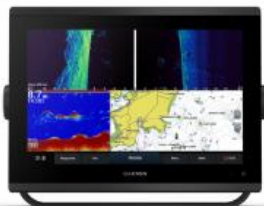

### GPSMAP I223xsv

MFD with multitouch 12" screen

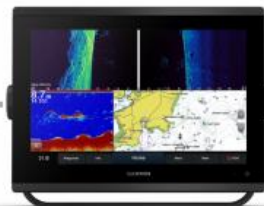

### Garmin GT15M-IH

Mid-Band CHIRP Traditional  
Depth and Temperature



## UPGRADE

2 GPSMAP 8416xsv (16") INSTEAD OF 2 GPSMAP I223xsv (12")

### GPSMAP 8416xsv + GPSMAP 8416

MFD with multitouch 16" screen and integrated sonar  
(Maps and sonar data are shared over the network)



## OPTION

BLACK-BOX VHF RADIO  
(AVAILABLE IN BOTH US/CANADA & INTERNATIONAL STANDARDS)

### VHF 315i

Black-box VHF Radio (1W / 25W)  
with GHS1i handset microphone





## OPTION

**AIS TRANSCEIVER**  
(VHF ANTENNA IS REQUIRED)

### AIS 800

AIS Transceiver (Built-in GPS  
and VHF antenna splitter)



## OPTION

**DOME RADAR**

### GMR FANTOM

18-inch, 40 W solid-state,  
dome radar with MotionScope  
Technology



## OPTION

**OPEN ARRAY RADAR**

### GMR Fantom 54

4' antenna, 50 W solid-state, open array  
radar with MotionScope Technology



HEIGHT OF OUTBOARD ENGINES SHAFTS

Modèle	Motorisation	Pied d'embase / Shaft length	Longueur en mm / Length in mm	Longueur en pouces / Length in inches	YAMAHA	MERCURY	HONDA	SUZUKI
CAP CAMARAT 12.5 WA	Tri-moteur / triple	1 x ULTRA LONG	722	30"	TU	XXL	XX	XX
		2 x EXTRA LONG	635	25"	TX	XL	X	X

RPM - SPEED - CONSUMPTION

Cap Cammet 12,5 WA							
		<b>YAMAHA 3x300cv</b>					
		<u>Caractéristique / Specifications:</u>					
		3 moteurs Hors Bord / 3 outboard engines:					F/FL300
		Hélice / Propeller:					T17SW
		Fuel tank capacity, theoretic					1150 L
Fuel safety %					20%		
Déplacement total du bateau / Total displacement of boat tested:						10150 Kg	
Regime en tours par minute au tableau de bord / RPM on instrument panel	Vitesse en nœuds moyenne au radar / Average speed on the radar in knots	Consommation moteur en litres par heure / consumption engine in liter an hour	Rendement / Efficiency (L/NM)	Consommation totale en USGal / heure Total consumption in USGal/h	Rendement / Efficiency (USGal/NM)	Autonomie en miles nautiques (avec réserve 20%) /Range in Nautical Miles (with 20% fuel safety)	Remarques / Comments
600	2,8 Nds	6,7 l	2,4L/NM	1,8 USGal/h	,63 USGAL/NM	384,48 NM	
1000	4,8 Nds	14,3 l	3,0L/NM	3,8 USGal/h	,78 USGAL/NM	309,89 NM	
1500	6,7 Nds	23,5 l	3,5L/NM	6,2 USGal/h	,92 USGAL/NM	262,86 NM	
2000	8,4 Nds	40,6 l	4,9L/NM	10,7 USGal/h	1,28 USGAL/NM	189,21 NM	
2500	9,3 Nds	62,9 l	6,8L/NM	16,6 USGal/h	1,79 USGAL/NM	136,03 NM	
3000	9,7 Nds	82,6 l	8,5L/NM	21,8 USGal/h	2,25 USGAL/NM	108,04 NM	
3500	12,5 Nds	113,7 l	9,1L/NM	30,0 USGal/h	2,40 USGAL/NM	101,19 NM	
4000	26,3 Nds	137,4 l	5,2L/NM	36,3 USGal/h	1,38 USGAL/NM	176,16 NM	
4500	31,0 Nds	174,4 l	5,6L/NM	46,1 USGal/h	1,49 USGAL/NM	163,53 NM	
5000	35,7 Nds	209,4 l	5,9L/NM	55,3 USGal/h	1,55 USGAL/NM	156,67 NM	
5500	38,8 Nds	253,6 l	6,5L/NM	67,0 USGal/h	1,73 USGAL/NM	140,58 NM	
5900	42,5 Nds	302,1 l	7,1L/NM	79,8 USGal/h	1,88 USGAL/NM	129,30 NM	
<u>Conditions optimales théoriques et purement indicatives des essais : /Optimal theoretical conditions, purely indicative for trials :</u>							
Coque neuve, vent 12nds, mer belle petit clapot, pas d'antifouling / new hull, wind 12 knots, nice little choppy sea, no antifouling, 600 L of water ballast for this test							

RPM - SPEED - CONSUMPTION

# BOAT HOUSE BULLETIN



A Factual Report from Mercury Marine

TEST CONDITIONS	
Test Date	06/11/2019
Test Conductor	STA
Boat Weight as Tested (kg)	10.3
Air Temperature (degrees C)	6
Elevation (m)	sea level
Sea State (calm / smooth / slight / moderate)	Slight
Wind Velocity range (kn)	20
Fresh Salt Water	Salt
Fuel Level at Testing (l)	Full

PERFORMANCE SUMMARY	
Top Speed (kn @ rpm)	45.5 @ 5900
Acceleration 0 - 20 kn (seconds)	10.1
Acceleration 0 - 30 kn (seconds)	16.2
Best Fuel Economy (nm/l @ rpm)	

### PERFORMANCE CURVE

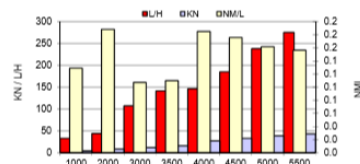

### PERFORMANCE DATA

RPM	SPEED	FUEL CONSUMPTION	
		L/H	NM/L
RANGE	KN		
1000	4.2	32.6	0.1
2000	8.2	43.6	0.2
3000	11.5	107.4	0.1
3500	15.5	141	0.1
4000	27	146	0.2
4500	32.5	185	0.2
5000	38.5	238	0.2
5500	43	275	0.2
5900	45.5	277	0.2

ENGINE SPECIFICATIONS	
Number of Engines	3
Engine	V8
Horsepower	300
Cylinders	4.2L
Drive or gear model and ratio	1.85:1

### BOAT SPECIFICATIONS

Region's sold	world
Manufacturer	JEANNEAU
Website	<a href="http://www.leanneau.fr">www.leanneau.fr</a>
Boat Model	cap camarat
Boat Type	Half Cabin - Fishing
Material	Fiberglass
Length (m)	12.5
Beam (m)	3.58
Max hp Capacity	900
Fuel Tank Capacity (l)	1200
Steering Type	JPO
Dry Boat Weight (kg)	5936
Mounting Bolt Hole (outboard)	2,4,2

### PROPELLER SPECIFICATIONS

Part Number	857027A46 LH
Part Number	8M0070052 RH
Part Number	857026A46 RH
Part Number	
Mercury Name	REVOLUTION 4
Material	SS
Diameter/Pitch	14 x x19 - 14 5/8 x20- 14 5/8 x19
Number of Blades	4

No painted hull, Genset equiped

Cruising speed trimmed 20 knots - 5700 rpm - 113L/h



MERCURY MARINE PO BOX 1539 FOND DU LAC, WISCONSIN 54936-1539

©2016 Mercury Marine. All Rights Reserved. Results on individual boats may vary depending on many factors.

800-MERCURY MERCURYMARINE.COM

CERTIFICATION CE

MODELES MODELS	ATTESTATION N° / CERTIFICATE N°	LONGUEUR	LARGEUR	CHARGE MAX / MAX LOAD	CATEGORIE / CATEGORY	PERSONNE S / PERSONS	PUISSANCE / MAXI POWER		MASSE MAXI MOTEUR / MAX ENGINE WEIGHT
		COQUE* / HULL LENGTH*	COQUE* / HULL BEAM*						
<b>CAP CAMARAT</b>		Mètres / Meters	Mètres / Meters	Kg			Kw	CV / HP	Kg
<b>Cap Camarat 12.5 WA</b>	<b>B SPB 19109 MM</b>	<b>10,66</b>	<b>3,54</b>	<b>3870 - 3 930</b>	<b>B - C - D</b>	<b>11 - 12 - 14</b>	<b>3 x 221</b>	<b>3 x 300</b>	<b>3 x 346</b>

**Pour les homologations en cours, toutes les informations doivent être considérées comme provisoires.**

**Les catégories et nombre de personnes indiqués correspondent à la demande faite par le chantier, pas à une confirmation.**

***When the EC regulation is in progress, please consider all information as provisional.***

***The categories and number of persons written are requested by the Jeanneau Yard, not confirmed.*** <sup>2</sup>

\* Indiqué sur la DEC (Déclaration Ecrite de Conformité)

\* *Written on the WSC (Written Statement of Compliance)*

ND: Non Disponible / No

Data

MOORING - ANCHORING KITS

Bateaux / Boats	MOUILLAGE / ANCHORING							AMARRE / MOORING		PARE-BATTAGES / FENDERS	
	Code / Ref	Ancre / Anchor		Chaîne / Chain		Câblot / Line		Code / Ref	Désignation / Détail	Code / Ref	Désignation / Détail
Cap Camarat 12.5 WA	162305	16 kg	Plate / Flat	10 mm	28m	40 m	18mm	043145	4 x D16 L12000	189033	6 x L.700 x D.250

**Information on batteries for outboard models**

**Information sur les batteries des modèles hors-bord**

Reminder: since 2016 season, batteries are NO MORE delivered with outboard boats (engine batterie(s), fridge battery, bow thruster battery).

Dealers have to order batteries by themselves and to add their prices in boat quotation.

Except for batteries, all other components (wiring, connectors, ...) are still delivered according to current rules, i.e in standard, in pre-riggings or in option. Hereunder you will find infos

Rappel: depuis la saison 2016, les batteries NE SONT PLUS LIVREES avec les bateaux hors-bord (batterie(s) moteur, batterie pour frigo, batterie de propulseur).

Les concessionnaires doivent commander eux-mêmes les batteries et inclure leur prix dans les devis clients.

En dehors des batteries, les autres composants (câblage, connecteurs, ...) continuent d'être livrés selon les inventaires actuels c'est-à-dire en standard, dans les pré-riggings ou en option

	Type 2		Type 3		Type 4		Type 6	
ref	220524		183615		061735		216629	
Description	95 AH DUAL AGM (starting		140 AH DUAL AGM		50 AH dry-fit starting battery		100 AH AGM starting battery	
Voltage (V)	12 V		12 V		12 V		12 V	
Capacity / Capacité (Ah)	95	20 h	140	20 h	50	20 h	100	20 h
Cranking / Intensité au démarrage (A)	850 CEN		750		750		870	
Endurance	360 cycles @ 50%		300 cycles @ 75%		500 cycles @ 75%			
Length / Longueur (mm)	353		513		260		330	
Width / Largeur (mm)	175		189		173		173	
Height / Hauteur (mm)	190		223		206		240	
Terminal position / Position des cosses								
Example / Exemple	Exide Technologie		Exide Technologie		Exide Technologie		Exide Technologie	
Indicative public price / Prix public indicatif (€ ex. VAT)	150 €		350 €		190 €		270 €	



**Information on batteries for outboard models**

**Information sur les batteries des modèles hors-bord**

Reminder: since 2016 season, batteries are NO MORE delivered with outboard boats (engine batterie(s), fridge battery, bow thruster battery).

Dealers have to order batteries by themself and to add their prices in boat quotation.

Except for batteries, all other components (wiring, connectors, ...) are still delivered according to current rules, i.e in standard, in pre-riggings or in option. Hereunder you will find infos

Rappel: depuis la saison 2016, les batteries NE SONT PLUS LIVREES avec les bateaux hors-bord (batterie(s) moteur, batterie pour frigo, batterie de propulseur).

Les concessionnaires doivent commander eux-mêmes les batteries et inclure leur prix dans les devis clients.

En dehors des batteries, les autres composants (câblage, connecteurs, ...) continuent d'être livrés selon les inventaires actuels c'est-à-dire en standard, dans les pré-riggings ou en option

	5.5 CC 5.5 WA 6.5 CC serie 3 6.5 WA serie 3	7.5 WA Serie 3 7.5 CC Serie 3	9.0 CC 9.0 WA	10.5 WA Serie2 10.5 CC	12.5 WA
Engine 1 / Moteur 1	Type 2	Type 2	Type 3	Type 2	Type 6
Engine 3 / Moteur 3	-	-	-	-	Type 6
Engine 2 / Moteur 2	-	-	Type 3	Type 2	Type 6
Fridge / Réfrigérateur / Service	-	Type 2		Type 2	Type 6 Type 6 Type 6 (qty = 3 batteries)
Genset option / Option générateur	-	-	Type 4	Type 4	Type 4
Bow thruster option / Option propulseur	-	Type 4	Type 4	Type 4 Type 4 (qty = 2 batteries)	Type 4 Type 4 (qty = 2 batteries)
Seakeeper option / Option Seakeeper	-	-	-		Type 6



This is not a contractual document.  
This document was updated in November 2023.  
It may contain illustrations or text representing  
or referring to optional equipment.  
If changes appear on our 2024 models,  
with regard to equipment or options referred to in this document,  
only the current Jeanneau rate will apply.



**JEANNEAU**