

MERRY FISHER

895 *SERIE 2*



SUMMARY

SPECIFICATIONS

KEY POINTS

EXTERIOR

INTERIOR

ATMOSPHERE

ELECTRONIC PACKS

TECHNICAL INFORMATION

Merry Fisher 895 Serie 2



Longueur hors tout / LOA

8,94 m / 29'4"

Longueur de coque / Hull length

7,98 m / 26'2"

Largeur maxi / Beam

2,99 m / 9'10"

**Tirant d'air (sans option /maxi option) /
air draft (wo option / with max option)**

min : 2,80 m / max : 3,25 m
min: 9'2" / max : 10'8"

Tirant d'eau coque / Hull draft

0,681 m / 2'3"

Déplacement léger / Displacement

4197 kg / 9250 lbs

Capacité de carburant / Fuel capacity

2 x 300 L / 2 x 79 USgal

Capacité eau / Fresh water capacity

160 L / 42 USgal

**Capacité eaux noires / Black water
capacity**

80 L / 21 USgal

Capacité de froid / Fridge capacity

65 L / 17 USgal

Cabines / Cabins

2

Couchages / Berths

4 / 6

Salles de bain / Heads

1

**Motorisation hors-bord max /
Outboard engines max**

2 x 250 HP + Joystick

**Designer & Architecte / Designer &
Architect**

Centkowski & Denert Design / Jeanneau
Design

Catégorie CE / CE certification

B 6 / C 10

Inspired by larger models

In 2023, the Merry Fisher 895 is renewed with a contemporary design and new equipment.

The Merry Fisher 855, a revolutionary boat launched in 2012, was the first powerboat of 8 meters on the market to offer two separate cabins. Its successor, the Merry Fisher 895, reinterpreted these attributes and has proven a very big success: over 1,800 have been cruising the world's seas since 2017. The new Merry Fisher 895 Serie2 thus becomes the third generation of 8-metre outboard powerboats with two separate cabins!

A proven design for peace of mind

Comfort and safety while cruising are essential points at the heart of developments from the Jeanneau design office and Centkowski & Denert. Developed by tank testing, the new hull form enables even faster planing and flat cruising, starting at intermediate speeds.

The Merry Fisher 895 Serie2 is offered with twin engines (up to 2 x 250 HP) to offer maximum comfort while cruising and manoeuvrability. It also benefits from the latest technology from our partner Yamaha for exceptional ease of use and a safer cruising experience.

At port, there is nothing like the joystick to simplify docking manoeuvres.

Comfortable modular exterior layouts

Inspired by flagships of the Merry Fisher line, the Merry Fisher 895 Serie2 offers spacious exterior living areas and incomparable functionality.

The large side door facilitates access from a quay or a dock and provides sea access from the cockpit for those who love to go for a swim!

The U-shaped cockpit, equipped with a folding portside bench seat and an optional large refrigerator, is ideal for experiencing moments of escape and relaxation.

Note, also, the new signature of the Merry Fisher line, a forward cockpit to guarantee safety and fluidity of movement about the boat. Children can then be well sheltered when seated, while adults enjoy the integrated sun loungers, or vice versa!

Comfort is omnipresent aboard a Merry Fisher 895 Serie2, with its aft cockpit that transforms into a sundeck, superior quality of outdoor upholstery, and oversized forward sun loungers, in the spirit of large cruisers.

Generous, inviting interior living spaces

On the interior, warmth is the watchword on board. The atmosphere is soft, harmonious, and refined, with grey walnut woodwork, Corian countertops in the galley, and contemporary upholstery.

Wide sliding glass doors, as well as windows in the hull and deck, diffuse a maximum of natural light into vast interior living spaces.

The practical, well-equipped galley features copious storage.

The rotating pilot seat in the saloon and the mini bar in the extension of the galley invite exceptional shared moments.

The two comfortable separate cabins and spacious head compartment are dedicated to the well-being of all on board.

This new weekender is perfectly designed to experience unforgettable family cruises, an incarnation of clever design by Jeanneau. Versatile and easy to handle, the Merry Fisher 895 Serie2 promises fun excursions with full peace of mind.

EXTERIOR

MERRY FISHER
895 *SERIE 2*



New Merry Fisher identity :

- **New shape of hull windows**
- Racy design and contemporary lines

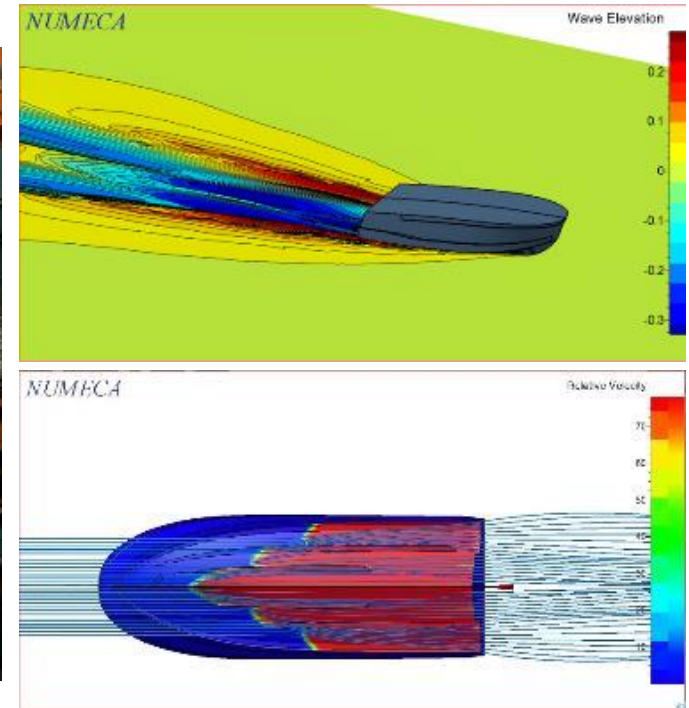

**NEW HULL OPTIMIZED FOR OUTBOARDS AND FLAT CRUISING AT INTERMEDIATE SPEEDS,
IN THE SAME SPIRIT AS THE HULL DEVELOPED FOR THE MERRY FISHER 1295 FLY.**

- 1 2 sliding roof hatches
- 2 Large glass windows surfaces : a lot of brightness
- 3 Wide side boarding door (on starboard)
- 4 Large hull window (new identity)
- 5 New optimized hull design



SAFE MANEUVERS & ACCESS ON BOARD



Starboard boarding door : easy access on board and safe swimming access

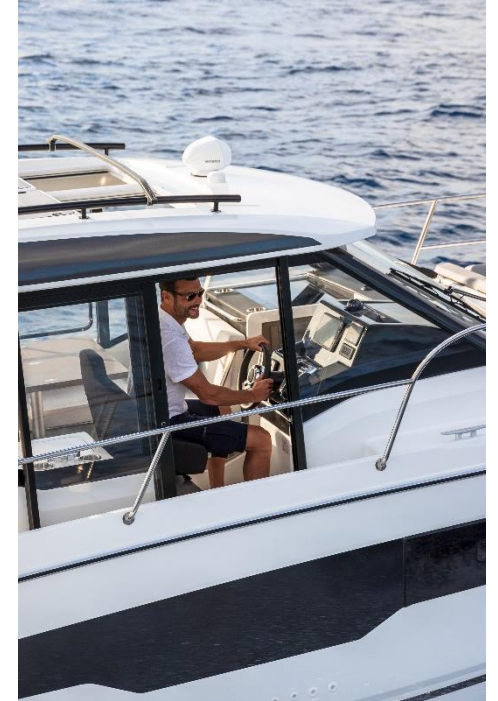

Pilot door on starboard

EXTERIOR

MERRY FISHER
895 *SERIE 2*

- 1 Large aft cockpit
- 2 Front cockpit/saloon and sunpad (optional filler cushion here for XXL sunpad)

→ Excellent circulation on board:
Easy access to the exterior, thanks to
the main starboard sidedeck

Secondary portside sidedeck



- 1** Main gate
- 2** Storage locker
- 3** Secondary gate
Removable backrest, easy access
to the portside platform and to
the shore plug
- 4** Aft cockpit table



EXTERIOR

L-shaped cockpit with :

- Sliding aft bench
- Folding bench on portside
- GRP table



MERRY FISHER
895 *SERIE 2*

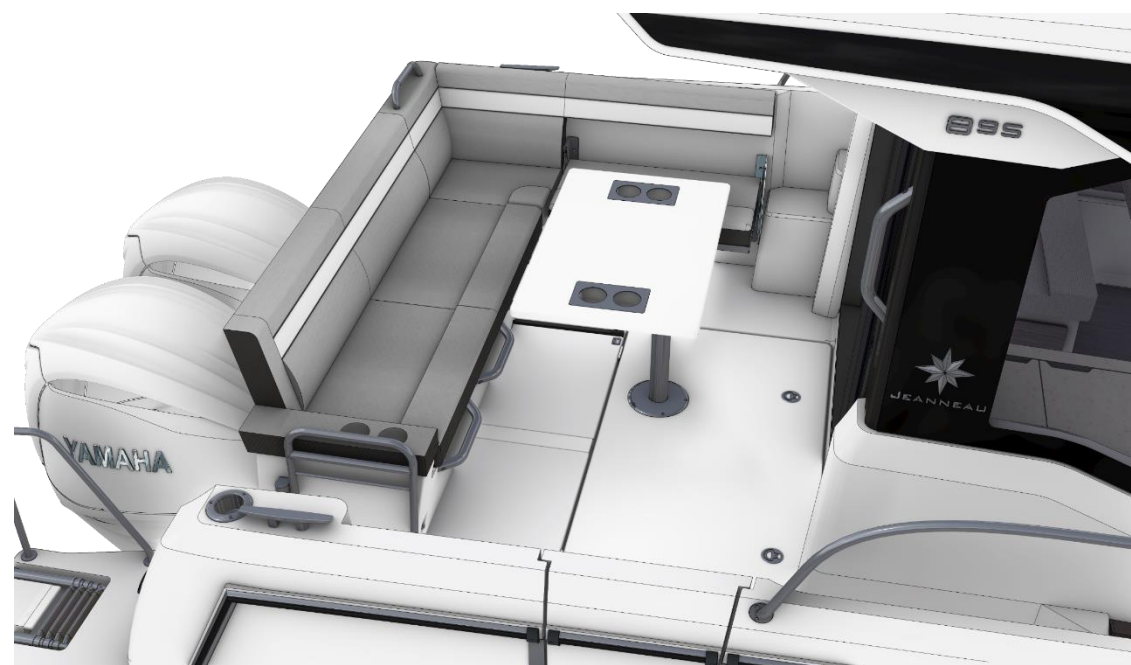

EXTERIOR

MERRY FISHER
895 *SERIE 2*

U-shaped cockpit with :

- Aft sliding bench
- Folding bench on portside
- GRP table
- Bench box against the wheelhouse
- Cushions for aft sunpad

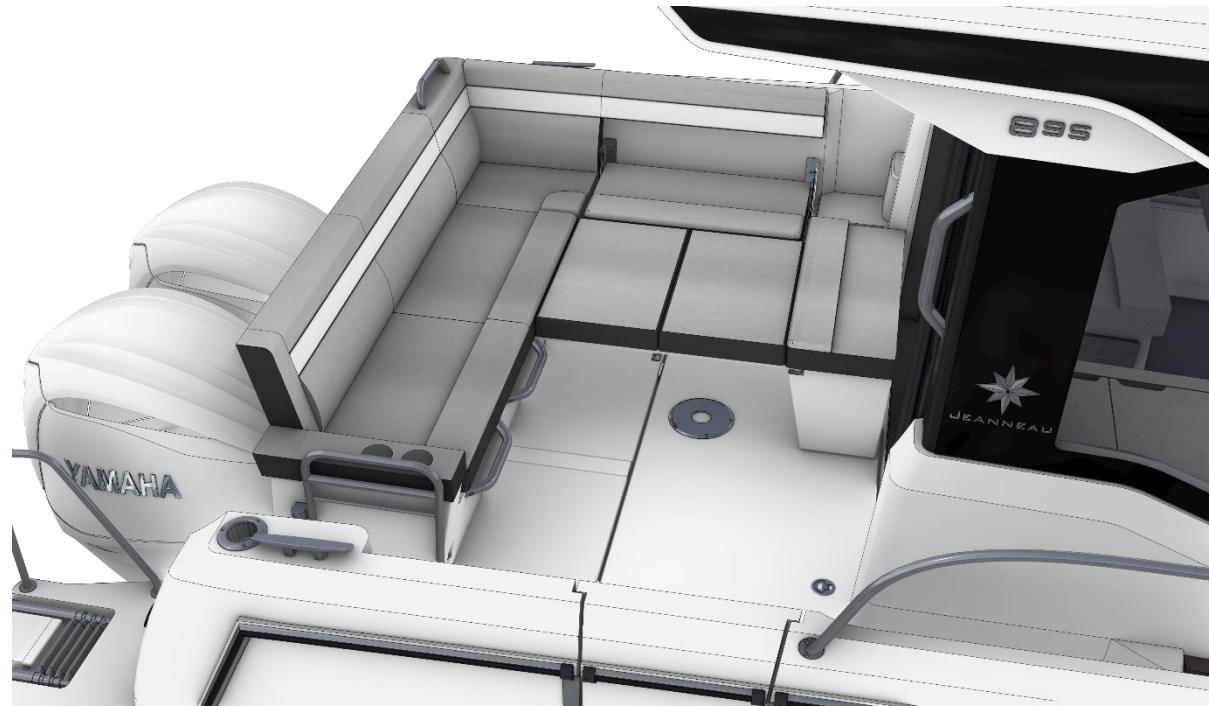
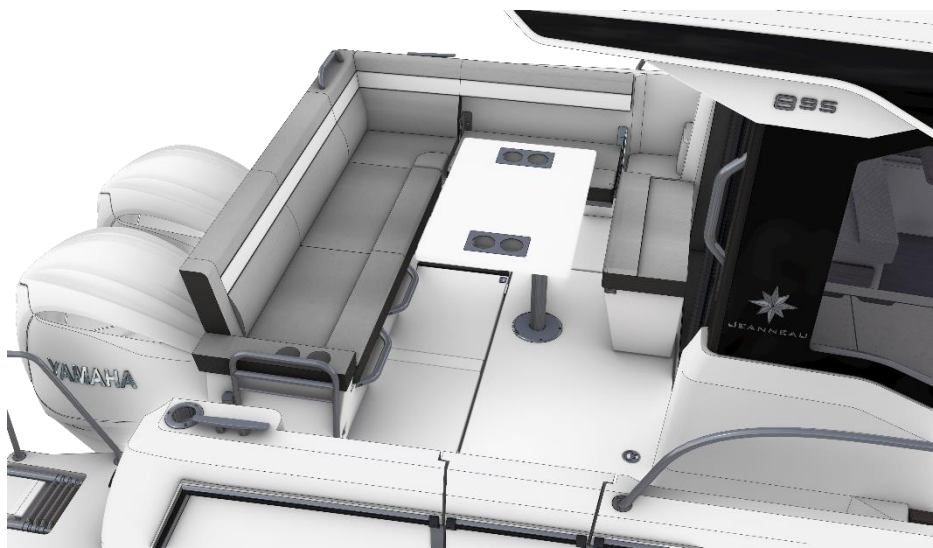

EXTERIOR

MERRY FISHER
895 *SERIE 2*

U-shaped cockpit option



EXTERIOR

MERRY FISHER
895 *SERIE 2*

Aft cockpit storage locker



Optional generator

EXTERIOR

MERRY FISHER
895 *SERIE 2*

Face-to-face front cockpit (optional XXL sunpad with bow cushion)



Front cockpit



2 bow seatings « Chaise longue »

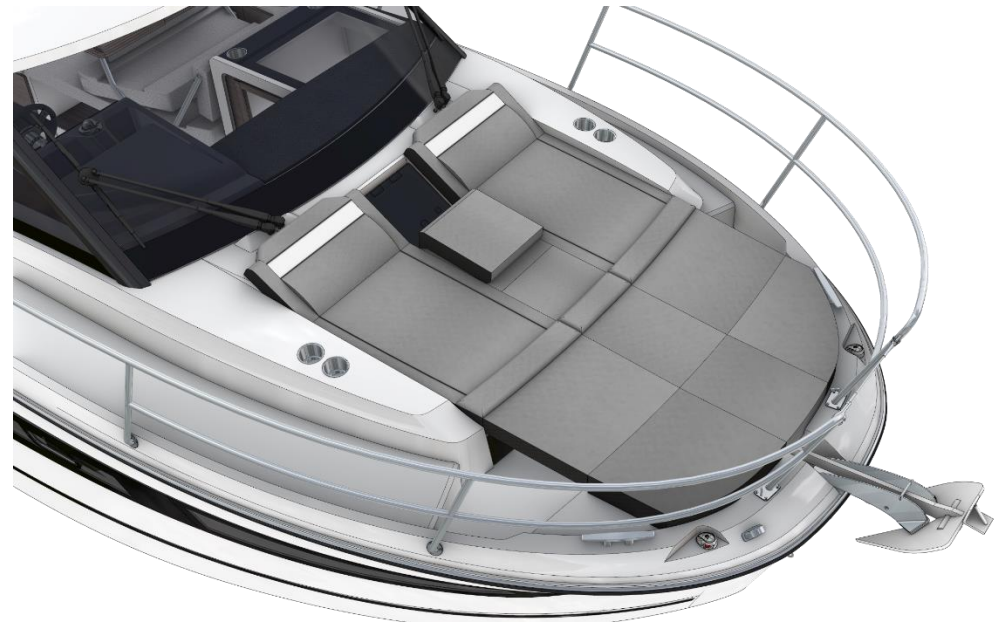

Extra filler cushions for XXL sunpad

Front cockpit

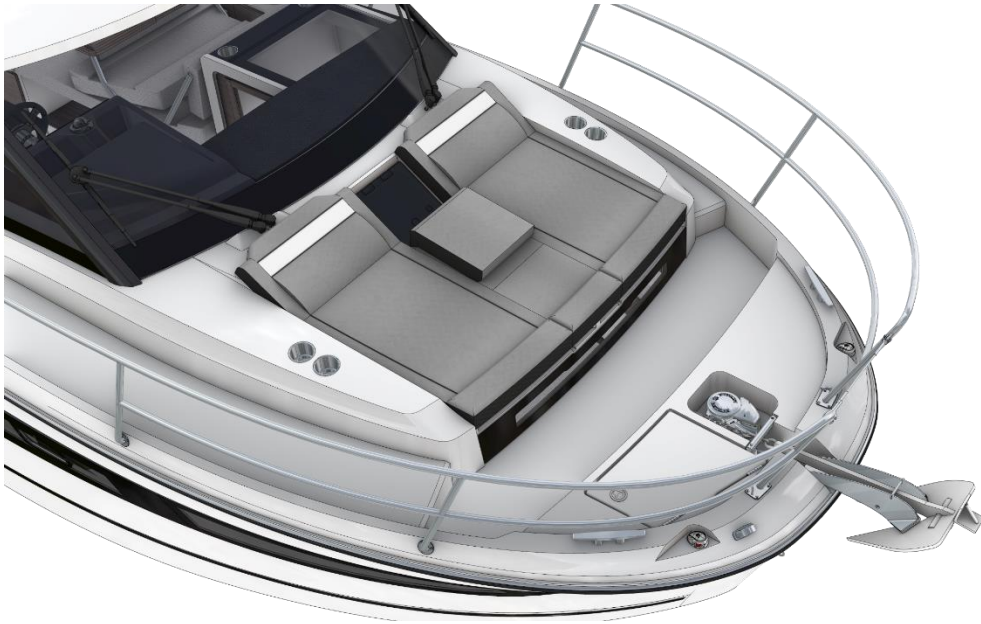

2 bow seatings « Chaise longue »

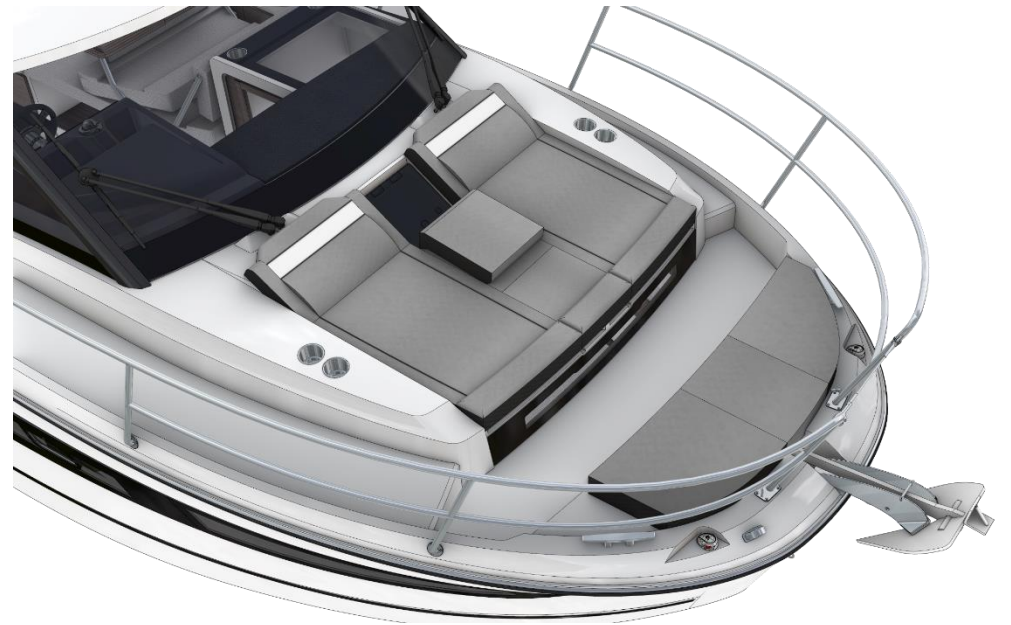

Face-to-face with bow cushion

INTERIOR

MERRY FISHER
895 *SERIE 2*

Large glass windows : a lot of brightness



VERY COMFORTABLE SALOON

- 1 Saloon
- 2 Rotating pilot seat (option)
- 3 Co-pilot bench with folding backrest



INTERIOR

MERRY FISHER
895 *SERIE 2*



INTERIOR

GALLEY LINKED TO THE COCKPIT

MERRY FISHER
895 *SERIE 2*

- 1 Storage furniture (option)
- 2 Folding bar (comfort pack)
- 3 Microwave oven (option)
- 4 Vitroceramic hob (option in leu of gas stove)
- 5 Sink



- 1 Spacious owner's cabin
- 2 Head
- 3 2nd separated cabin with double bed

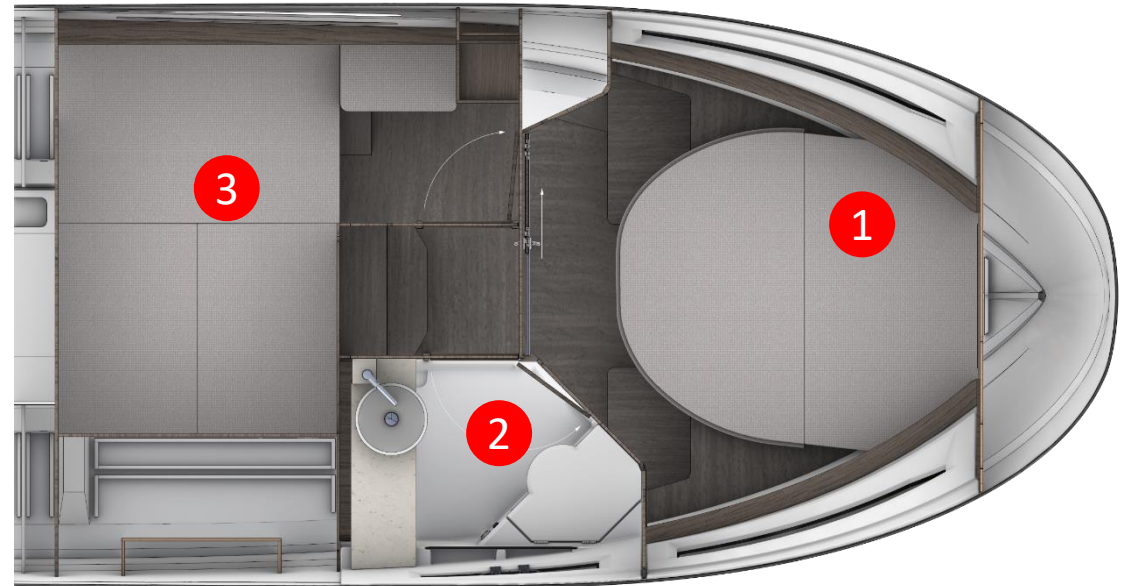

OWNER'S CABIN

- 1 Opening deck hatch and skylight
- 2 Large hull windows
- 3 Storage (option)
- 4 Large storage under the bed



GUEST CABIN

1 Hull window with opening porthole

2 Double bed

3 Wardrobe

4 Seating



HEAD

- 1 Electric WC
- 2 Storage
- 3 Corian worktop

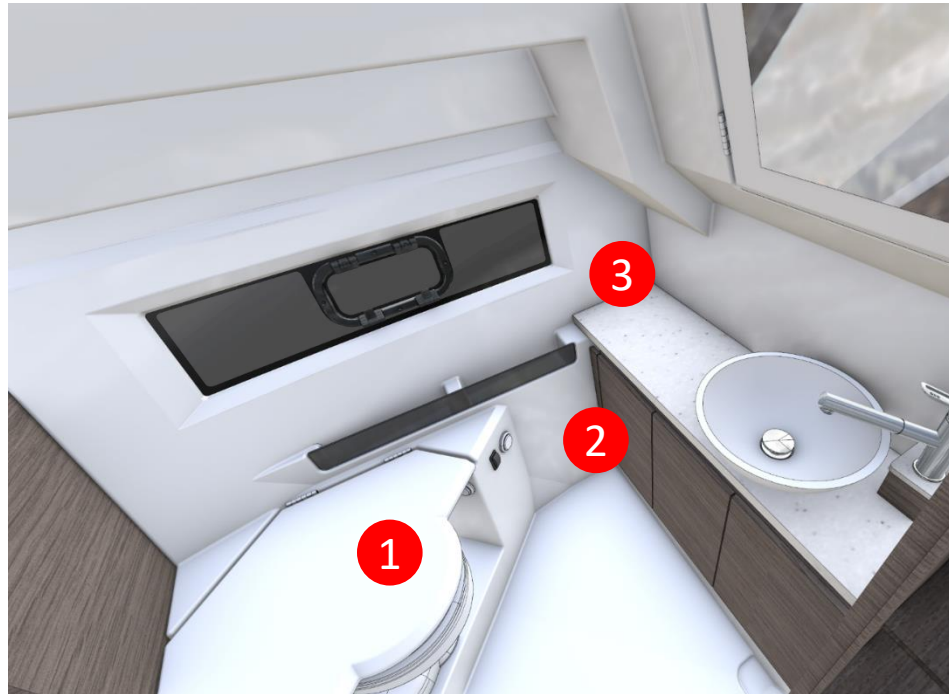

EXTERIOR

SELLERIE
UPHOLSTERY
STANDARD

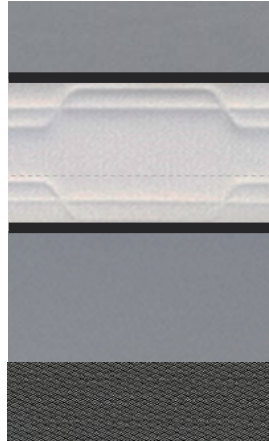

DIAMANTE MOONLIGHT
SPRADLING HITCH ICEBERG
DIAMANTE CARBON

CAPOTAGES
AWNINGS



SUNBRELLA
GRAPHITE

TOILES D'OMBRAGE
SUN AWNINGS

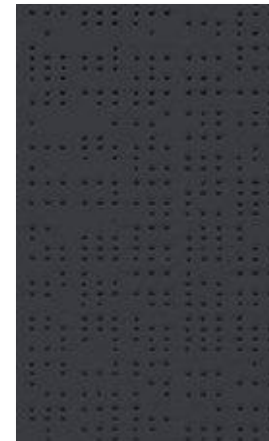

SOLTIS 92

INTERIOR

TISSU INTÉRIEUR
FABRIC INTERIOR

STANDARD



JUMBO PURE

TISSU INTÉRIEUR
FABRIC INTERIOR



DOLCE ARTESIAN

MENUISERIES
WOOD

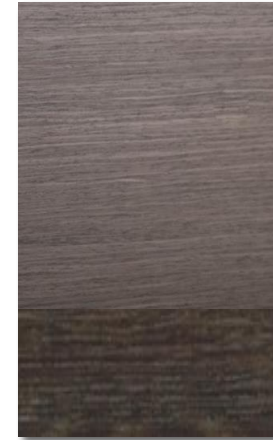

**NOYER GRISÉ /
PLANCHER CHÊNE BRUN**

ELECTRONIC PACK

ECHOMAP UHD2 92sv
Chartplotter/Sonar combo with 9"
keyed-assist touchscreen display.



Garmin GT15M-IH
Mid-Band CHIRP Traditional
Depth and Temperature

UPGRADE

1 GPSMAP I223xsv (12") INSTEAD OF AN ECHOMAP UHD2 92sv (9")

GPSMAP I223xsv

MFD with multitouch 12" screen
and integrated sonar



OPTION

FIXED-MOUNT VHF RADIO
(AVAILABLE IN BOTH US/CANADA & INTERNATIONAL STANDARDS)

VHF 215i AIS

VHF radio with integrated AIS receiver
(1W / 25W)



Merry Fisher 895 S2



YAMAHA 2x200cv

Caractéristique / Specifications:

2 moteurs Hors Bord / Out Board engines: F200 SBW

Hélice / Propeller: T15 RELIANCE

Déplacement total du bateau / Total displacement of boat tested: 5703 Kg

Regime en tours par minute au tableau de bord / RPM on instrument panel	Vitesse en nœuds moyenne au radar / Average speed on the radar in knots	Consommation moteur en litres par heure / consumption engine in liter an hour	Rendement / Efficiency (NM/L)	Consommation totale en USGal / heure Total consumption in GPH	Rendement / Efficiency (NM/USGal)	Autonomie en NM (avec réserve 20%) /Range in NM (with 20% fuel supply)	Remarques / Comments
600	2,7 Nds	3,2 l	1,2l/miles	,8 USGal	4,5 GAL/NM	405,00 MN	
1000	3,8 Nds	6,4 l	1,7l/miles	1,7 USGal	6,4 GAL/NM	285,00 MN	
1500	5,5 Nds	10,4 l	1,9l/miles	2,7 USGal	7,2 GAL/NM	253,85 MN	
2000	7,2 Nds	16,9 l	2,3l/miles	4,5 USGal	8,9 GAL/NM	204,50 MN	
2500	8,2 Nds	25,2 l	3,1l/miles	6,7 USGal	11,6 GAL/NM	156,19 MN	
3000	9,3 Nds	37,1 l	4,0l/miles	9,8 USGal	15,1 GAL/NM	120,32 MN	
3500	11,7 Nds	51,1 l	4,4l/miles	13,5 USGal	16,5 GAL/NM	109,90 MN	
4000	16,5 Nds	67,7 l	4,1l/miles	17,9 USGal	15,5 GAL/NM	116,99 MN	
4500	25,0 Nds	79,9 l	3,2l/miles	21,1 USGal	12,1 GAL/NM	150,19 MN	
5000	28,9 Nds	107,0 l	3,7l/miles	28,3 USGal	14,0 GAL/NM	129,64 MN	25% trim
5500	33,3 Nds	138,0 l	4,1l/miles	36,5 USGal	15,7 GAL/NM	115,83 MN	50% trim
6000	35,5 Nds	154,0 l	4,3l/miles	40,7 USGal	16,4 GAL/NM	110,65 MN	75% trim

Conditions optimales théoriques et purement indicatives des essais : /Optimal theoretical conditions, purely indicative for trials :

Coque neuve, vent 5nds, mer belle petit clapot, pas d'antifouling / new hull, wind 5 knots, nice little choppy sea, no antifouling

Merry Fisher 895 S2



YAMAHA 2x250cv

Caractéristique / Specifications:

2 moteurs Hors Bord / Out Board engines: F250 SBW

Hélice / Propeller: T15 SALTWATER

Déplacement total du bateau / Total displacement of boat tested: 5583 Kg

Regime en tours par minute au tableau de bord / RPM on instrument panel	Vitesse en nœuds moyenne au radar / Average speed on the radar in knots	Consommation moteur en litres par heure / consumption engine in liter an hour	Rendement / Efficiency (NM/L)	Consommation totale en USGal / heure Total consumption in GPH	Rendement / Efficiency (NM/USGal)	Autonomie en NM (avec réserve 20%) /Range in NM (with 20% fuel supply)	Remarques / Comments
600	2,4 Nds	5,0 l	2,1l/miles	1,3 USGal	7,9 GAL/NM	230,40 MN	
1000	4,3 Nds	10,0 l	2,3l/miles	2,6 USGal	8,8 GAL/NM	206,40 MN	
1500	6,5 Nds	16,2 l	2,5l/miles	4,3 USGal	9,4 GAL/NM	192,59 MN	
2000	7,9 Nds	26,6 l	3,4l/miles	7,0 USGal	12,8 GAL/NM	142,56 MN	
2500	9,2 Nds	40,6 l	4,4l/miles	10,7 USGal	16,7 GAL/NM	108,77 MN	
3000	11,1 Nds	53,2 l	4,8l/miles	14,1 USGal	18,2 GAL/NM	100,15 MN	
3500	16,4 Nds	68,3 l	4,2l/miles	18,0 USGal	15,8 GAL/NM	115,26 MN	
4000	26,5 Nds	89,6 l	3,4l/miles	23,7 USGal	12,8 GAL/NM	141,96 MN	
4500	30,7 Nds	117,0 l	3,8l/miles	30,9 USGal	14,4 GAL/NM	125,95 MN	
5000	35,5 Nds	148,0 l	4,2l/miles	39,1 USGal	15,8 GAL/NM	115,14 MN	20% trim
5500	37,3 Nds	189,0 l	5,1l/miles	49,9 USGal	19,2 GAL/NM	94,73 MN	40% trim
6000	39,2 Nds	194,0 l	4,9l/miles	51,2 USGal	18,7 GAL/NM	96,99 MN	50% trim

Conditions optimales théoriques et purement indicatives des essais: /Optimal theoretical conditions, purely indicative for trials :

Coque neuve, vent 5nds, mer belle petit clapot, pas d'antifouling / new hull, wind 5 knots, nice little choppy sea, no antifouling

Longueur d'arbres moteurs / Engines shaft length

Modèle	Motorisation	Pied d'embase / <i>Shaft length</i>	Longueur en mm / <i>Length in mm</i>	Longueur en pouces / <i>Length in inches</i>	YAMAHA	MERCURY	HONDA	SUZUKI
MERRY FISHER 895 Serie² / 895 Sport	bi-moteur / twin	EXTRA LONG	635	25"	TX	XL	X	X

Mouillage & amarrage / Anchoring & mooring

Bateaux / Boats	MOUILLAGE / ANCHORING							AMARRE / MOORING		PARE-BATTAGES / FENDERS	
	Code / Ref	Ancre / Anchor		Chaîne / Chain		Câblot / Line		Code / Ref	Désignation / Détail	Code / Ref	Désignation / Détail
Merry Fisher 895 Serie ² Merry Fisher 895 Sport	162304	14 kg	Plate / Flat	8 mm	23m	35m	14mm	043143	4 x D12 L8000	189031	4 x 645 x D.150

Certification CE / EC certification

MODELES MODELS	ATTESTATION N° / CERTIFICATE N°	LONGUEUR COQUE* / HULL LENGTH*	LARGEUR COQUE* / HULL BEAM*	CHARGE MAX / MAX LOAD	CATEGORIE / CATEGORY	PERSONNES / PERSONS	PUISSANCE / MAXI POWER		MASSE MAXI MOTEUR / MAX ENGINE WEIGHT	
		Mètres / Meters	Mètres / Meters	Kg			Kw	CV / HP	Kg	
Merry Fisher 895 Serie 2	en cours / In progress	7,98	2,97	1927	B - C	6 - 10	2 x 186	2 x 250	2 x 320	
Merry Fisher 895 Sport	RCDB 0000092		2,94		2200	C	10	2 x 130	2 x 200	2 x 315
Merry Fisher 895 Sport Offshor	RCDB 0000092				1880 - 2200	B - C	6 - 10	2 x 186	2 x 250	2 x 315

Pour les homologations en cours, toutes les informations doivent être considérées comme provisoires.

Les catégories et nombre de personnes indiqués correspondent à la demande faite par le chantier, pas à une confirmation.

When the EC regulation is in progress, please consider all information as provisional.

The categories and number of persons written are requested by the Jeanneau Yard, not confirmed.

* Indiqué sur la DEC (Déclaration Ecrite de Conformité)

* *Written on the WSC (Written Statement of Compliance)*

ND: Non Disponible / No Data

TECHNICAL INFORMATION

MERRY FISHER
895 *SERIE 2*

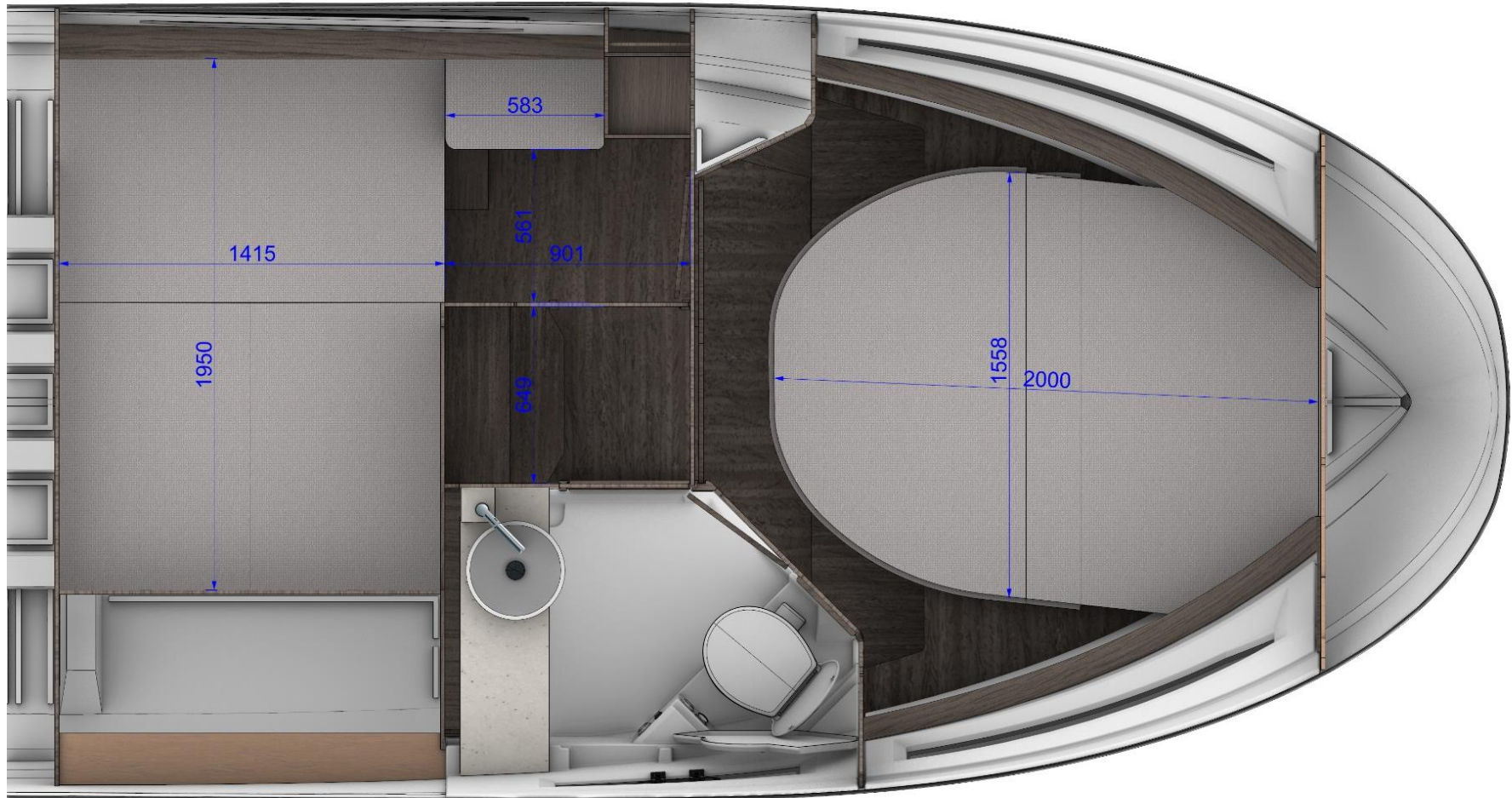

TECHNICAL INFORMATION

MERRY FISHER 895 *SERIE 2*

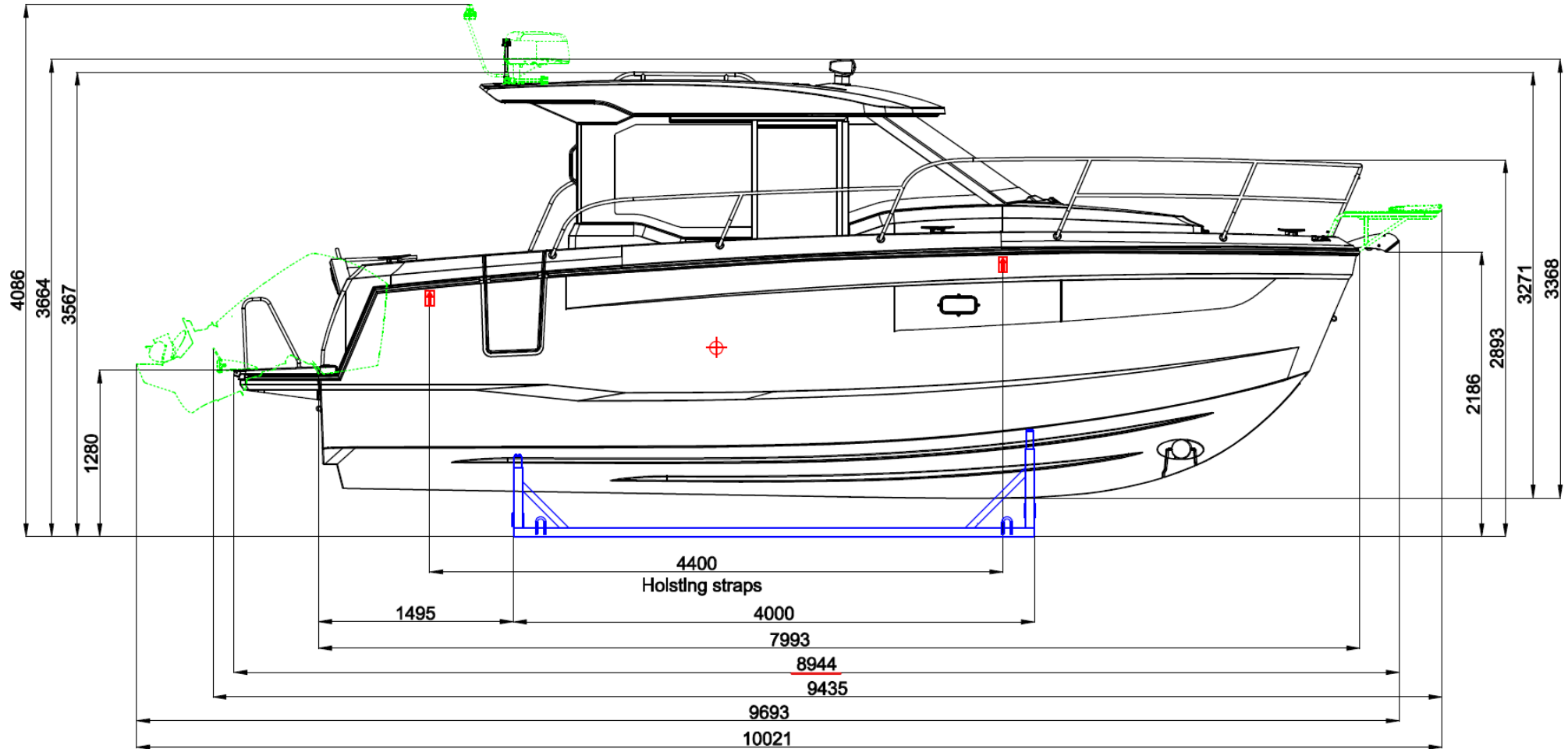

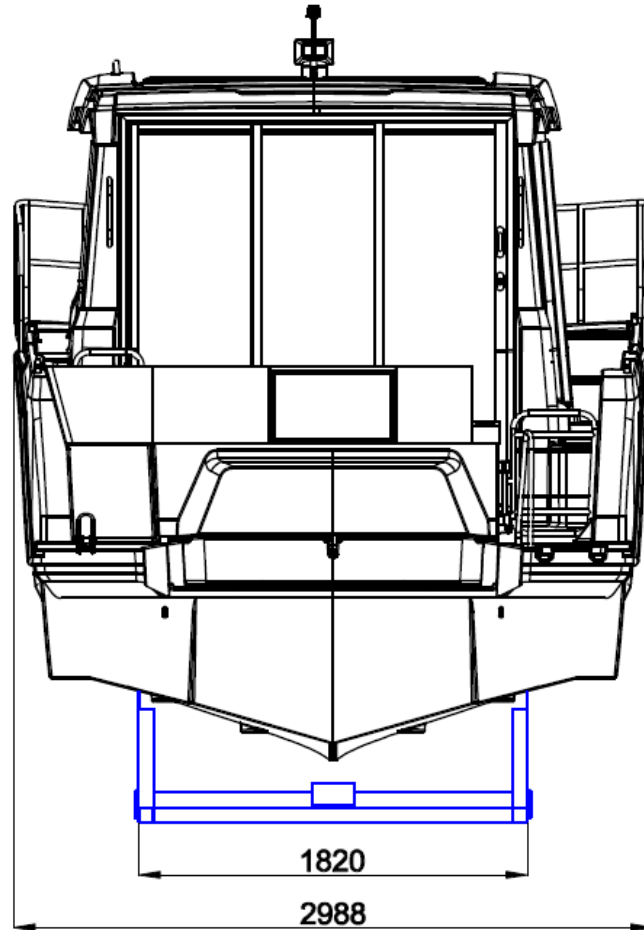

M E R R Y F I S H E R

895 *SERIE 2*

This is not a contractual document.

This document was updated in October 2023.

It may contain illustrations or text representing or referring to optional equipment. If changes appear on the next model year, with regard to equipment or options referred to in this document, only the current Jeanneau rate will apply.



J E A N N E A U